



Design Analysis and Implementation of A 0.5 KVA Uninterruptible Power Stabilizer

Aghanwa Sunny¹, S.O. Ezeonu¹ and S. O. Ezennaya^{2*}

¹Department of Physics and Industrial Physics, Nnamdi Azikiwe University, P.M.B. 5025, Awka, Anambra State, Nigeria.

²Department of Electrical Engineering, Nnamdi Azikiwe University, P.M.B. 5025, Awka, Anambra State, Nigeria.

Authors' contributions

This work was carried out in collaboration between all authors. Author SOE wrote the protocol, managed the analyses of the study and literature researches. Author SOE did the mathematical design and developed a model that described the input-output relationships and wrote the first draft of the manuscript. Author AS performed the statistical analysis, managed the literature searches and laboratory experiments and implementation. All authors read and approved the final manuscript.

Article Information

DOI: 10.9734/PSIJ/2017/31535

Editor(s):

- (1) Aleksey Anatolievich Zakharenko, The International Institute of Zakharenko Waves (IIZWs), Krasnoyarsk, Siberia, Russia.
(2) Christian Brosseau, Distinguished Professor, Department of Physics, Université de Bretagne Occidentale, France.

Reviewers:

- (1) G. K. Nisha, University of Kerala, Kerala, India.
(2) Prashant Kumar, Shivaji University, Maharashtra, India.

Complete Peer review History: <http://www.sciencedomain.org/review-history/18189>

Method Article

Received 12th January 2017
Accepted 17th February 2017
Published 14th March 2017

ABSTRACT

This paper presents design analysis and implementation of a 0.5 KVA uninterruptible electronic power stabilizer (UPSz). Poor and instability of power supply delivery in Nigeria necessitated the need for a device that can stabilize voltage, protect equipment from damages and also provide power to the loads in the absences of electricity from the utility mains. This need motivated the design of a power stabilizer (UPSz). Method of Pulse with modulation (PWM) was adopted. This method is capable of modulating a varying input to a stabilized output. Two input sources were considered; a fluctuating 220 V volt mains supply and a constant 12 V battery. The 12 V battery was rectified to provide an AC power supply to the load in the absence of the utility mains. The control circuit ensured a stabilized output voltage from input range of 140 V to 260 V AC power supply which is about $\pm 40V$ to the usual supply voltage from the utility mains of 180V-220V in Nigeria. Appropriate protection circuits were incorporated against surges to which ensured the safety of home/office appliances. A variac was used to obtain various AC voltage levels during the

*Corresponding author: E-mail: so.ezennaya@unizik.edu.ng;

testing. The voltage and current results at different loadings (in watts) of the UPSz were obtained. These results were compared with those of commercially readily available offline UPS of the same rating. The UPSz unlike the commercially available types delivered a stabilized voltage of 220 V to different loads of 60 W to 400 W range at a fluctuating input voltage range of 140 V to 260 V. This showed that the designed UPSz is an improved and better device than the offline equivalent. Other advantages include portability (light weight) and less expensive (relatively cheap).

Keywords: Uninterruptible power supply; stabilizer; variac; pulse width modulation.

1. INTRODUCTION

The need for reliability in power supply has obviously been with humanity for many years. With the increase use of electrical power and electronic device, the urge for continuous electric power supply and reliability has become an increasing concern. In developing countries such as Nigeria, the grid is still very unstable. Several blackouts and disruptions during the day are not unusual. Even highly developed countries such as Germany experience an average of 100 mains failures per year lasting less than 20 ms and about 30 failures lasting between 20 ms and 1s [1]. Alternating current power problems have been recognized by the utility companies, computer manufacturers and end users as a subject that must be addressed. The power problems extend from spikes, noise and frequency variations to complete black-outs. These problems can be corrected individually using surge suppressors, filters, regulators, and amplifiers. The use of uninterruptible power supply system (UPS) can collectively solve all these problems [2] rather solving them independently.

2. THE UNINTERRUPTIBLE POWER SUPPLY (UPS)

The UPS is a unit composing of a range of solid-state devices, which are interconnected based on their respective functional principles to provide required unit function of protection against power supply aberrations and failure. Because these units are composed of solid state devices they are often described as static UPS units, as opposed to rotary systems which are based on motor/generator technology [3]

A UPS typically does two things [4]: It either provides power to enable the safe shutdown of equipment and saving data to a non-volatile medium, or it provides power to equipment over the duration of mains fault/failure, enabling equipment to operate continuously.

The uninterruptible power equipment which were called the no-break power supplies were of rotary design. These appeared during the 1950's. [5] stated that the need for it at that time was related to defense equipment such as communication and radar. Although, many arrangements and devices were tried by the year 1939 to 1945 for military purpose during the war to supply continuous power to communication equipment in military bases. The development obviously continued after the war. The research became more focused on achieving greater reliability, increase efficiency and reduction in maintenance. In accordance to this, a breakthrough occurred in the 1950's and was called the no-break power supply. The operation of the no-break power supplies was for power to be supplied through the rectifier to the DC motor which is in turn powered an AC generator. On loss of mains, the battery became the energy source and enabled the generator to supply uninterruptible power.

In time, various rotary systems in the UPS were changed and replaced with solid state device which led to increase in performance, efficiency, duration, reduced cost and wide application use. As time goes on, the UPS has become a product that no business can do without, appearing in various forms such as the offline UPS, online UPS and line interactive with its use basically essential in areas with constant power failure, electrical disturbance or fluctuations.

It is clearly evident that for every electrical and electronics equipment, power is required for their operation. And for these equipment to operate properly and at maximal output they must operate within the voltage range for which they are designed otherwise damage to equipment and appliances will occur. According to [6], the situation of voltage fluctuation is very common within the Nigeria power supply system owing to a number of reason ranging from over loading of supply lines and transformers to fluctuation caused by external transient and induction of power lines etc. The offline UPS is the most

widely sold and used UPS around the world followed by the line interactive UPS. The shortcomings associated with the offline include;

- Zero ability to stabilize or condition input voltage levels
- Provided little or no surge protection

There is evident need of protection device such as the automatic voltage regulator, stabilizers etc to limit the fluctuation of electrical power to the home appliances at a safe voltage range and at the same time providing uninterruptible power to the same appliance. This device would ensure that power outages, sags, surges, harmonics etc are prevented from adversely affecting the performance of the device. [7] stated that electronic gadgets nowadays are increasingly being equipped with digital circuitries for increased functions and better performance. These digital circuits are very sensitive to fluctuation and power outages. All applications of digital electronics and computer-based system are worse hit by problems of power supply. Hence the need for a device that incorporates the stabilization of power output and can also temporarily supply power for the duration of power outage were highly recommended.

For the above reason, technically incorporating a voltage stabilizer into the working principles of an offline UPS was done in this work which produced an enhanced and more functional offline UPS. The stabilizer helps to regulate the output voltage to the load so that the load would receive a normal voltage of 220 V.

Latest technologies in this field includes parallel processing line interactive uninterruptible power supply for sudden voltage fluctuation for power management, Uninterruptible power supply using solar rechargeable battery, a micro-controlled multi-powered uninterrupted power supply system, fuzzy logic controlled uninterruptible power supply integrating renewable energy. Most of which are focused on increasing the use of the UPS during battery mode, the UPSz is focused on eliminating damages and malfunctions originated by voltage fluctuation.

3. UNINTERRUPTIBLE POWER STABILIZER (UPSz)

An interruptible power stabilizer (UPSz) is a device that has both the ability of an offline UPS combined with that of a voltage stabilizer. While

the stabilizer unit regulates the voltage spikes, under voltage, surge protection with other unprecedented effect produced by voltage fluctuation, the UPS unit provides the DC voltage to the load when the main grid or power supply fails.

The main focus of the UPSz is to prevent voltage fluctuations and its resulting consequence during supply of power to the connected load when acting as an intermediary between the load and the power supply line ensuring that a stable AC power is supplied to the load. It will also ensure that the load receives uninterrupted power when main power from the grid gets interrupted.

4. DESIGN ANALYSIS AND IMPLEMENTATION OF UPSz

The UPSz operation involves two modes and within it are arranged solid state devices which ensure the proper operation of each mode. Though the system was designed to be simple, it is made up of two major parts which consist of the hardware and software. A microcontroller was used to achieve easy triggering of the MOSFET switches during conversions. It was also used to issue commands to the various relays for specific actions. Pulse width modulation (PWM) techniques were adopted for the generation of pulses used for switching.

4.1 List of Components

Microcontroller (PIC16RA76A), Diodes, Crystal oscillator, Opto-coupler, Resistors, Operational amplifier (LM358), Transistor, Transformer (220V/12V), Bridge Rectifier, Voltage regulator (7805), Double winding transformer, Capacitors, LEDs (light emitting diodes), Electromechanical Buzzer, Rechargeable Battery, Metal oxide semiconductor field effect transistor (MOSFET).

The block diagrams of the system, alongside the simplified version are shown below.

4.2 Mode of Operation

The device was designed to operate on two modes;

- Mode I = Mains ON
- Mode II = Mains OFF

4.2.1 Mode I operation

When power is supplied from the mains, mode I is activated and power flow to the two rectifier's

K1 and K2 as shown in Fig. 1. Mode I has two branches; branch one and branch two. Branch one is the power stabilization unit while branch two is the simple power supply unit, (battery charging unit).

ensures that mode I stabilizes the utility power supply to 220 volts.

4.2.1.1 Branch one of mode I: the power stabilization unit

Rectification (Rectifier, K1): The block labelled K1 in Fig. 1 is an AC-DC converter consisting of full bridge, four (4) diode rectifiers connected in the fashion shown in the circuit diagram of Fig. 3.

The power stabilization unit consists of rectification and inversion. These in addition to overvoltage/under voltage protection circuits

The AC power supply from the mains is first converted into direct current by rectifier k1 and filtered by the LC passive filter to smoothen the output voltage.

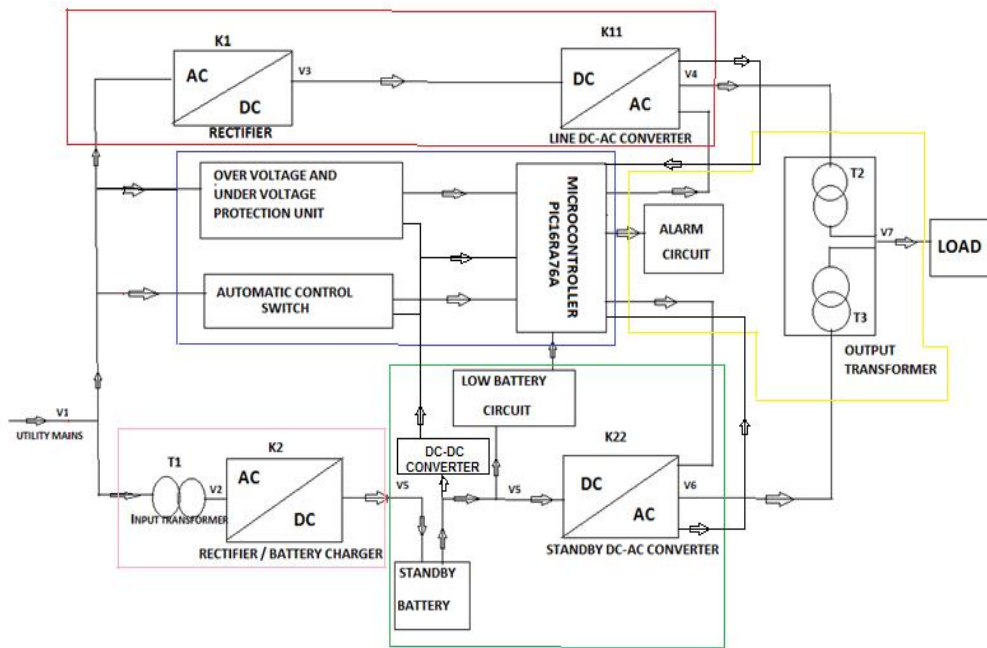

Fig. 1. Block diagram of the UPSz

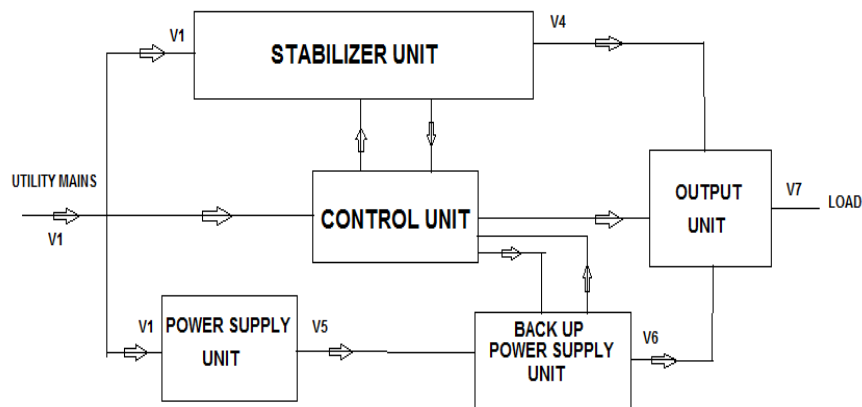

Fig. 2. Simplified block diagram

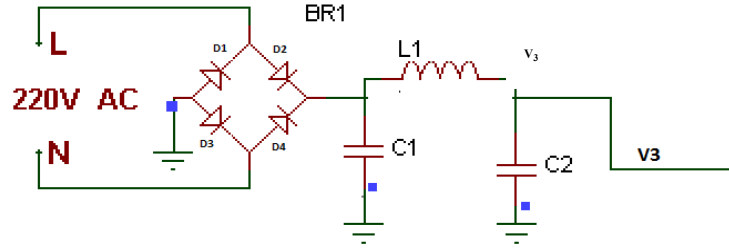

Fig. 3. Circuit diagram of the rectifier (k1) with filters

Mathematically,

The standard full bridge rectifier output voltage is given by;

$$V_{dc} = \frac{2}{2\pi} \int_{\alpha}^{\pi} V_m \sin \omega t \quad [8] \quad (1)$$

Which when evaluated gives;

$$V_{dc} = \frac{V_m}{\pi} (\cos \alpha + 1) \quad (2)$$

For a diode, $\alpha = 0$.

Thus

$$V_{dc} = \frac{2V_m}{\pi} \quad (3)$$

Where

$$\begin{aligned} V_m &= V_3 \\ V_m &= \text{Mains Voltage } (V_s) * \sqrt{2}, \end{aligned} \quad [9] \quad (4)$$

The max voltage entering the rectifier = V_m
 $\alpha =$ firing angle. Diodes cant be fired and so have zero firing angle.
 $V_s = V_1 =$ voltage from the mains = 220V

Therefore

$$\begin{aligned} V_m &= 220 \times \sqrt{2} = \mathbf{311.12V} \\ V_m &= 311.12V \end{aligned}$$

Therefore,

$$V_{dc} = \frac{2 \times 311.12}{3.142} = \mathbf{198V}$$

Hence $V_{dc} = V_3$.

The efficiency of the rectifier K1 is given by

$$\begin{aligned} \eta &= (\text{Output voltage} / \text{Input voltage}) \times 100 \quad [9] \quad (5) \\ &= (198V/220V) \times 100 = 0.9 \times 100 = 90\% \end{aligned}$$

And so the efficiency of the rectifier K1 is 90%

Inversion (line DC-AC converter, K11):

Converter K11 converts the rectifier output voltage, $V_{dc} = V_3$ back to an alternating voltage, V_4 . The line DC-AC converter (K11 as labelled in Fig. 1) operates during mode I and gets its input DC voltage source from the output of rectifier K1. The MOSFETs used by the converter is IRF3205N – channel MOSFET connected in half-bridge fashion. Where Q_2 and Q_3 shown in Fig. 4, represents the MOSFET switches used.

The converter uses a half bridge technique to produce the required AC voltage into the primary of the output transformer. From the circuit diagram in Fig. 4, the gates of the MOSFETs Q_2 and Q_3 get their gate pulse from pin 21 and pin 22 of the microcontroller through the 1k Ω resistor while the V_4 is connected to the transformer (T_2) tapings. It is such that when Q_2 is switched ON, Q_3 is switched off and current flows through to the transformer winding (T_2) and when Q_3 is turned ON, Q_2 is OFF also current flow through the transformer winding (T_2). The switching ON and OFF of the MOSFETs channels will start an alternating current in the winding of the output transformer T_2 . This way an AC power is transferred from the output transformer to the load.

The standard half-bridge DC-AC converter output voltage is given as;

$$V_o = \sum_{n=1,3,5,\dots}^{\infty} \frac{2}{\pi} \left[\int_0^{2\pi} \frac{V_{dc}}{2} \sin n\omega t \, d\omega t \right] \quad [10] \quad (6)$$

This is simplified to get;

$$V_{on} = \sum_{n=1,3,5,\dots}^{\infty} \frac{2V_{dc}}{n\pi} \sin n\omega t \quad (7)$$

Thus;

$$V_{on \, rms} = \frac{2V_{dc}}{n\pi\sqrt{2}} \times \frac{\sqrt{2}}{\sqrt{2}} = \frac{2\sqrt{2}V_{dc}}{n\pi 2} = \frac{\sqrt{2}V_{dc}}{n\pi} \quad (8)$$

Where n is the harmonics introduced by the switching of the MOSFETs.

Where V_{dc} is the source voltage which is **198V**

Thus the fundamental V_{orms} value is given by;

$$V_{o1\ rms} = \frac{2 * 198}{1 * \pi \sqrt{2}} = \frac{\sqrt{2} * 198}{1 * \pi} = \mathbf{89.12V}$$

The voltages for the first five harmonics gotten as;

$$V_{(3)} = V_{fund} / 3 \tag{9}$$

$$V_{(3)} = 89.12 / 3 = \mathbf{29.7V}$$

$$V_{(5)} = V_{fund} / 5 \tag{10}$$

$$V_{(5)} = 89.12 / 5 = \mathbf{17.8V}$$

$$V_{(7)} = \mathbf{12.7V}, V_{(9)} = \mathbf{9.9V}, V_{(11)} = \mathbf{8.1V}$$

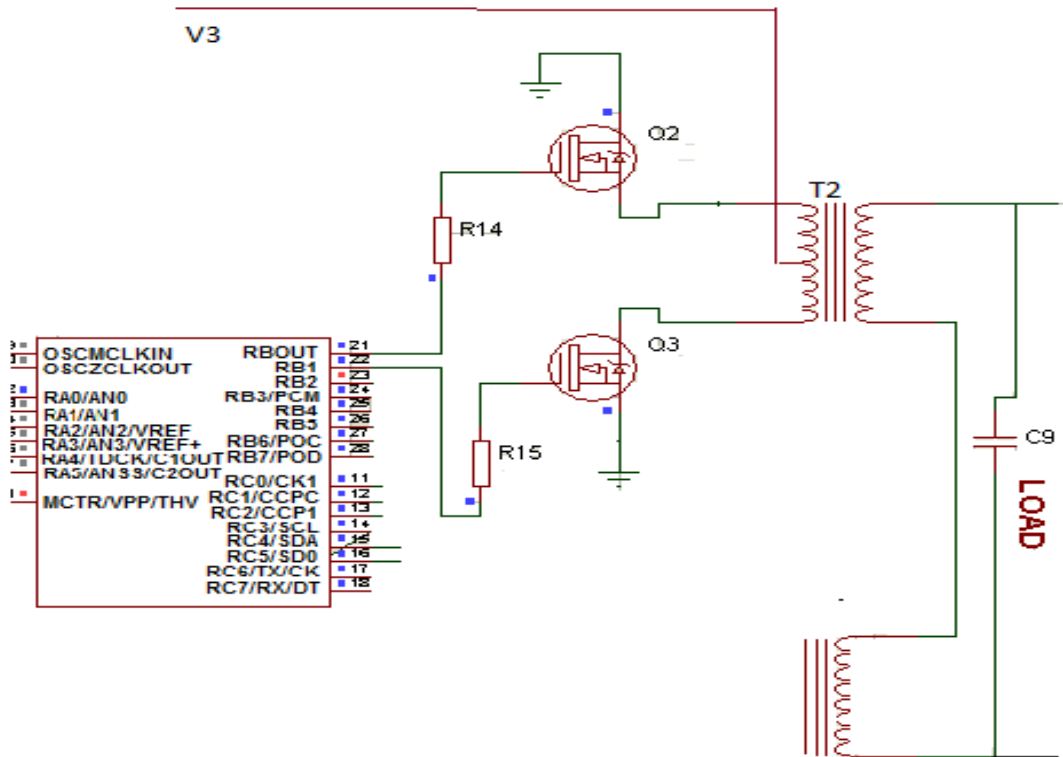

Fig. 4. Half-bridge DC-AC converter connected to a microcontroller

The RMS value by harmonic summation method

$$V_{0\ rms} = \sqrt{(V^2_{(fund)} + V^2_{(3)} + V^2_{(5)} + V^2_{(7)} + V^2_{(9)} + V^2_{(11)})} \tag{11}$$

$$V_{0\ rms} = \sqrt{(89.12^2_{(fund)} + 29.7^2_{(3)} + 17.8^2_{(5)} + 12.7^2_{(7)} + 9.9^2_{(9)} + 8.1^2_{(11)})}$$

$$V_{0\ rms} = \sqrt{9466.2} = 97.29V$$

Thus the converter output voltage, V_4 as indicated in Fig. 1, is calculated to be;

$$V_{0\ rms} = 97.29V = V_4$$

This output voltage of the converter is then fed to the center-tap transformer T_2 as labelled in Fig. 1.

Efficiency of the line DC-AC converter is obtained as

Efficiency (η) = (output power / input power) x 100%

$$\eta = \frac{V_{0\text{ rms}} * I}{V_{dc/2} * I} = \frac{V_{0\text{ rms}}}{V_{dc/2}} = \frac{97.29}{198/2} * 100\% = 98\%$$

Therefore the line DC-AC converter has an efficiency of 98%.

4.1.2.2 Branch two of mode I: power supply unit

The branch two of mode I is the power supply unit responsible for charging of the battery, B1. The AC power from the mains was stepped down using 220/12V transformer T_1 before supplying to rectifier, K2. The output of the transformer is in a ratio proportional to the voltage required to charge the battery.

The standard output voltage of the rectifier K2 is given by the same equation (2) through to (5)

Where in this case,

$V_{dc} = V_s$, $V_m = \text{Mains Voltage } (V_s) * \sqrt{2}$,
 $\alpha = \text{firing angle. Diodes cant be fired and so have zero firing angle.}$

$V_s =$ Secondary voltage of the stepped down transformer = $V_2 = 12V$

The max voltage entering the rectifier = V_m . Therefore from the transformer to the rectifier

$$V_2 = V_s = V_{out} \text{ from the transformer,}$$

$$V_m = V_s * \sqrt{2}$$

$$= 12V * \sqrt{2} = 16.97V$$

The output DC voltage from the rectifier can be gotten by,

$$V_{dc} = V_s = 2V_m / \pi$$

$$V_{dc} = \frac{2 * 16.97}{3.142} = 10.8V$$

10.8V DC is the voltage being filtered by the capacitor. A voltage regulator of 7812 series was used to regulate and maintain the DC output at 12V. The 12V is feed to the battery in order to charge it. The battery automatically starts to charge whenever the main supply is available.

To obtain the efficiency of the rectifier K2, same approach as in rectifier k1 was adopted and is given by;

$$\eta = \frac{\text{output power}}{\text{input power}} * 100\% \tag{12}$$

$$\eta = \frac{10.8V * I}{12V * I} * 100 = 0.9 * 100 = 90\%$$

Where I is current.

Thus the efficiency of the rectifier K2 is 90% which corresponds to the efficiency of rectifier k1.

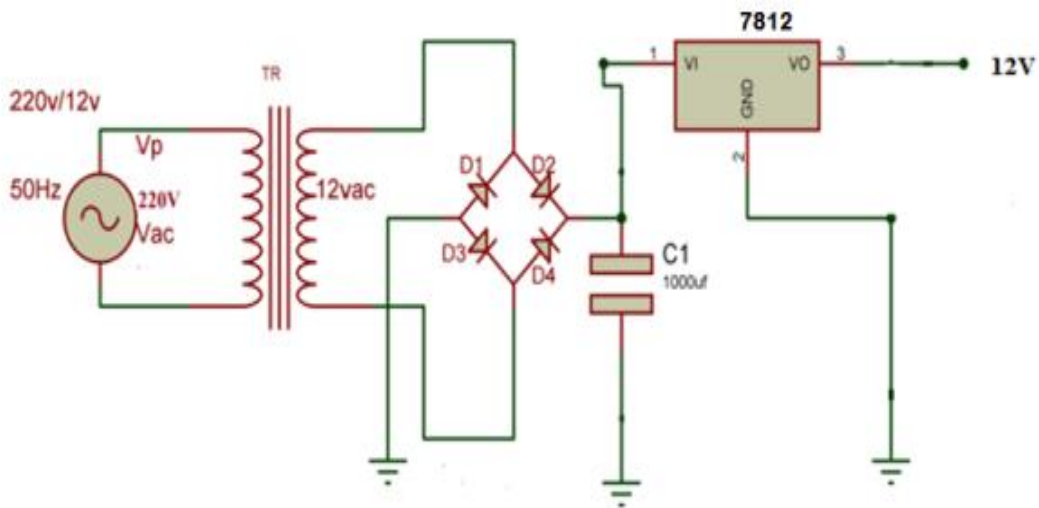

Fig. 5. Circuit diagram of the rectifier K2 with transformer T_1

4.2.2 Mode II operation (back up power supply)

This is when the power from the utility is interrupted and the load is automatically connected to the output of the standby DC-AC converter, k22. The automatic changeover is achieved using static switches incorporated to the microcontroller. The switching is in microseconds. This mode consists of a 12V battery (standby battery), a DC-DC converter, low battery circuit and a (standby) DC-AC converter supplying the power to the load.

4.2.2.1 The battery, B1

The battery used for the design of the UPSz is a 50Ah, 12V lead acid battery. It has a power factor (Pf) of 0.8 as stated on its name plate. Thus, the minimum acceptable voltage level at which the battery can function effectively is $12 \times 0.8 = 9.6V$ (An assumption of 10 volt minimum was made in this work to take care of tolerance as shown in Table 1) while the maximum acceptable level for charging the battery is 14.4V (An assumption of 14V was made in the work for tolerance purpose).

The performance of mode II depends on the connected battery. The battery backup time can be calculated thus;

Battery backup time = (battery Ampere-hour (AH) x battery voltage (V) x Number battery (N) x efficiency of the battery (η) \div load in watts

$$\text{Backup-Time} = \frac{\text{AH} \times \text{V} \times \text{N} \times \eta}{\text{W}} \quad [11] \quad (13)$$

Where battery AH = 50Ah, Efficiency (η) = 0.8 (worse power factor for standard home appliance always written on the name plate of the

appliances), Battery voltage = 12V, N = 1 battery, Load = 400 W.

Therefore,

$$\begin{aligned} \text{Backup-Time} &= \frac{50 \times 12 \times 1 \times 0.8}{400} \\ &= 1.2 \text{ hours} = 1 \text{ hour } 12 \text{ mins} \end{aligned}$$

NB: for a lesser load (in watts), the back-up time becomes more.

4.2.2.2 The DC-DC converter

A DC – DC converter circuit shown in Fig. 6 was connected to the battery so as to supply a power of 5 v to the control unit.

The 12V standby battery supplies power to the DC-DC converter (DC regulator of 7805 series); at this point, capacitor, C3 begins to filter out the ripples contained in the regulated DC voltage. The voltage regulator regulates the input 12V to 5V. Capacitor, C4 of the value $100\mu\text{F}/25\text{V}$ filters the 5V output voltage to remove ripples that might be present.

The main advantage of using this very type of linear DC-DC converter is because it is easy to construct and also purchase. Making it easily replaceable if damaged. It has an efficiency of 45% which is typical for linear regulators.

4.2.2.3 The standby DC-AC converter, K22

This converter, K22 just like converter, k11 uses a half bridge technique in producing the required AC output voltage to the primary of the output transformer T_3 . Its input voltage is from a 12V standby battery. To calculate the output voltage, V_6 (labelled in Fig. 1) from this converter, K22, same equation governs the process.

Table 1. Design specifications

Specification	Symbol	Values
Nominal I/P AC Voltage	V_{IN}	220V
Maximum I/P AC Voltage	V_{INMax}	260V
Minimum I/P AC Voltage	V_{INMin}	140V
Nominal I/P DC Voltage	V_{in}	12V
Maximum I/P DC Voltage	$V_{in Max}$	14V
Minimum I/P DC Voltage	$V_{in Min}$	10V
Nominal O/P Power	P_{out}	400W
Nominal Output Voltage	V_{out}	220V
Target efficiency	η	>90%
Switching frequency	f	50KHz
Device rating		500VA

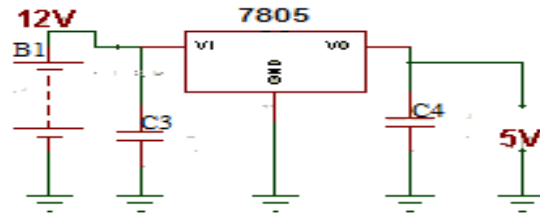

Fig. 6. Diagram of the DC-DC converter connected to the battery (B1)

Where V_{dc} is the source voltage of the battery which is 12V

Thus the fundamental V_{orms} value is given by;

$$V_{o1rms} = \frac{2*12}{1*\pi\sqrt{2}} = \frac{\sqrt{2}*12}{1*\pi} = 5.4V$$

As long as switching is concerned, harmonics have to be present which is due to switching transient.

$$V_{(3)} = V_{fund} / 3 \quad (14)$$

$$V_{(3)} = 5.4 / 3 = 1.8V$$

$$V_{(5)} = V_{fund} / 5 \quad (15)$$

$$V_{(5)} = 5.4 / 5 = 1.08V$$

$$V_{(7)} = 0.77V, V_{(9)} = 0.6V, V_{(11)} = 0.49V$$

The RMS value by harmonic summation method

$$V_{0rms} = \sqrt{(V^2_{(fund)} + V^2_{(3)} + V^2_{(5)} + V^2_{(7)} + V^2_{(9)} + V^2_{(11)})}$$

$$V_{0rms} = \sqrt{(5.4^2_{(fund)} + 1.8^2_{(3)} + 1.08^2_{(5)} + 0.77^2_{(7)} + 0.6^2_{(9)} + 0.49^2_{(11)})}$$

$$V_{0rms} = \sqrt{34.7594} = 5.895V$$

Thus the converter output voltage, V_6 as indicated in Fig. 1 is calculated to be;

$$V_{0rms} = 5.895V = V_6$$

This output voltage of the converter is then fed to the centre-tap transformer T_3 as labeled in Fig. 1. Efficiency of the standby DC-AC converter is obtained as;

$$\text{Efficiency } (\eta) = \frac{V_{0rms} * I}{V_{dc/2} * I} = \frac{V_{0rms}}{V_{dc/2}} = \frac{5.895}{12/2} = 98 \quad (16)$$

Therefore the line DC-AC converter has an efficiency of 98%.

The gates of the MOSFETs Q_4 and Q_5 get their gate pulse from pin 15 and pin 16 of the microcontroller through the 1k Ω resistor while the V_{dc} is connected to the MOSFETs channels. It is such that when Q_4 is switched ON, Q_5 is switched off and current flows through to the transformer winding (T_3) and when Q_5 is turned ON, Q_4 is OFF also current flow through the transformer winding (T_3). The switching ON and OFF of the MOSFETs channels will start an alternating current in the winding of the output transformer T_3 . This way an AC power is transferred from the output transformer to the load.

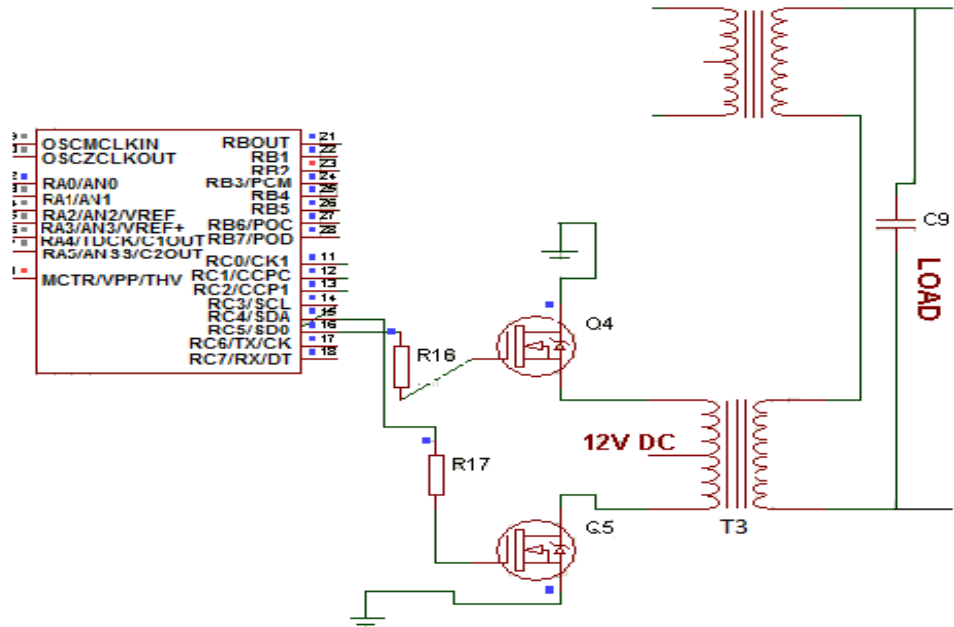

Fig. 7. Circuit diagram of the standby DC-AC converter interfacing the transformer T₃

Note: Both modes (mode I and mode II) are controlled by the microcontroller to achieve the fast execution of the separate operation. Protection circuits were incorporated within Mode I to take care of the voltage fluctuations

4.2.2.4 Low battery circuit

This is the circuit that monitors and sends signals to the microcontroller when the voltage of the battery drops to a level of about 10V. The microcontroller monitors the change in the threshold of the battery output voltage and runs a quick shut down program to turn the device off once a certain threshold has been reached.

4.3 The Pulse Width Modulation (PWM)

Voltage stabilization was achieved by controlling the duty cycle of the MOSFET switches using pulse width modulation (PWM). This process majorly affects or concerns the varying AC supply voltage from the mains and it is associated by two comparison process called under voltage and over voltage control process. Pulse width modulation method offers excellent performance such as light line, load regulation and stability during voltage variations [12].

PWM (pulse width modulation) is the approach used to control the ON and OFF time (duty cycle) of the associated power switches (IRF3205N – channel MOSFET). Naturally, a change in the input voltage will result to an immediate change in the output voltage which means that a variable

input voltage would produce a variable output voltage. Therefore, to obtain a constant output voltage from a variable input voltage, the voltage and current level of the input voltage has to be adjusted in order to achieve a constant output voltage as expected. In other words, pulse width modulation involves adjusting the width of the pulse required to switch the MOSFETs gate open and close so as to adjust the voltage and current level passing through the gate of the MOSFETs to produce the required output power.

The precise PWM pattern used to control the gate of the MOSFETs Q₂ and Q₃ is determined by an error detection circuit in the microcontroller which monitors the output voltage and increases or decreases the mark-to-space ratio of the PWM drive signal as necessary in order to maintain the correct output voltage. In order to achieve stabilization of the output voltage, the processor system in the microcontroller monitors the frequency and phase of the utility voltage for maintaining synchronism between the DC-AC converter output and the incoming mains (output of the rectifier K1). The synchronism was done by a zero cross over detector in the microcontroller PIC16RA76A which monitors the zero cross over point of the utility voltage, this

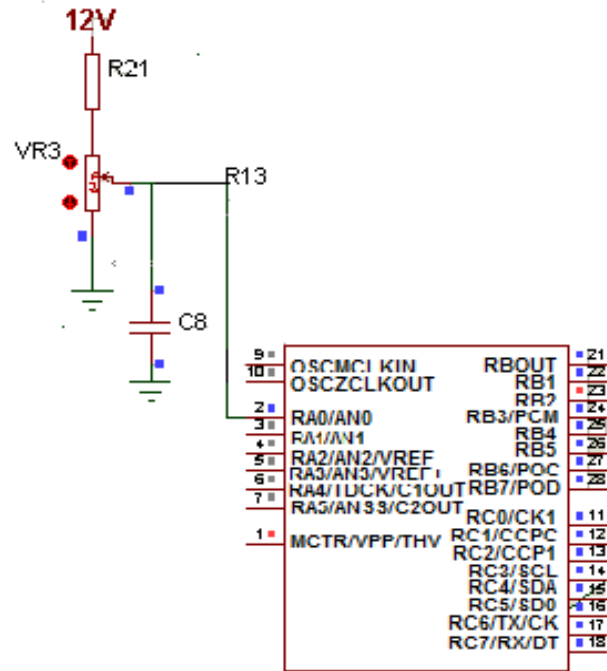

Fig. 8. The low battery circuit interfacing with the microcontroller

provides the processor with both frequency and phase information. This information is needed so as to adjust the mark-to-space ratio of the PWM drive signal which controls the gate of the MOSFETs.

By controlling the gate of the MOSFETs Q_2 and Q_3 with the precise PWM drive signal, the output voltage and current of the line DC-AC converter was regulated to give the desired output power to the terminals of the transformer. The transformer (T_2) then steps up the input power to the required output power. If the filtered output from the AC-DC converter (which is the input voltage of line DC-AC converter) tends to change, the feedback applied to the PWM controller varies the duty cycle to maintain a constant output voltage. The gates of the MOSFETs are driven by the microcontroller PIC16RA76A with a pulse frequency of 50 KHz.

5. CONTROL UNIT

The control unit is responsible for proper and active functioning of the UPSz. It controls voltage regulations processes, monitors the presence of power from various sources and ensures that the load is not affected by any consequences of voltage fluctuations or irregularities. The control unit consist of the microcontroller, an automatic

control switch and the under voltage/over voltage protection circuits.

5.1 THE MICROCONTROLLER (PIC16RA76A)

The microcontroller used is called the PIC16RA76A and it is a powerful 200 nano second instruction excuter, easy to program (35 single word instructions), CMOS FLASH based 8-bit microcontroller. It has 28 pin package and it is compatible with the PIC16C5X, PIC12CXXX and PIC16C7X devices. It features include 256 byte of EEPROM data memory, self-programming, 2 comparators, 5 channels of 10-bit analog-to-digital (A/D) converter, 2 capture/compare/PWM functions. All this features makes it ideal for more advanced level A/D application in automotive applications, industrial appliances and consumer applications.

It is basically the heart of the entire circuitry. The microcontroller is used as the central control element for many primary functions such as generation of the PWM drive wave form monitoring the output voltage, DC-AC output current for overload and short circuit protection, phase and frequency locking of the output and input power supply.

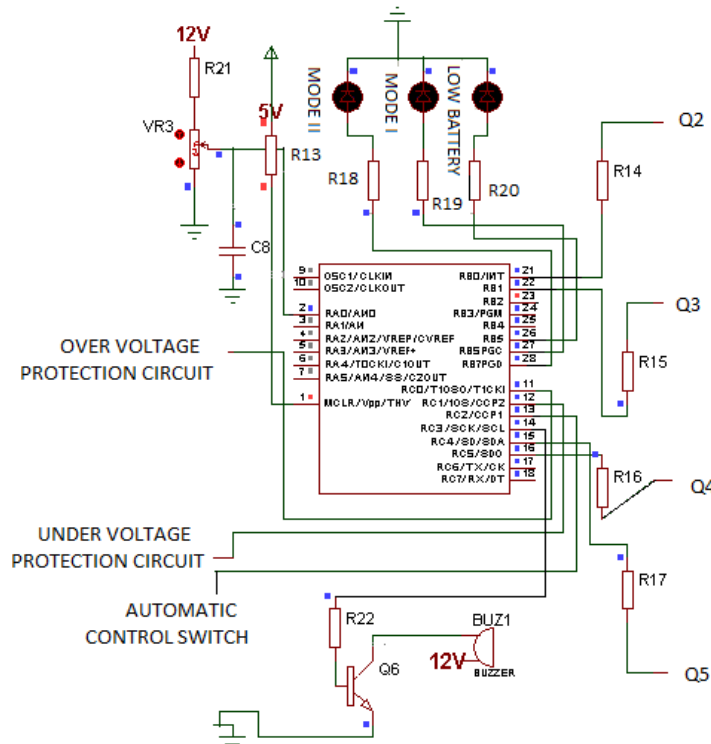

Fig. 9. The microcontroller interfacing various sections of the UPSz

5.2 Automatic Control Switch

The automatic control switch aims at signaling the microcontroller about the absence or interruption of power from the utility mains in order for a different source of power to be activated to serve the load. This section is responsible for producing the signal needed by the microcontroller in switching the entire system from mode I to mode II and vice versa. It involves the use of an opto-isolator feeding an NPN transistor to produce a HIGH or a LOW at its output which in turn is used to signal the microcontroller to switch modes.

5.3 Over Voltage and Under Voltage Protection Circuits

This circuit was designed to monitor the input voltage from the mains and alert the microcontroller of the occurrence of an overvoltage or under voltage. It does this by producing a HIGH or a LOW output signal to the pins of the microcontroller. The circuitry comprises of an operational amplifier configured as a comparator to compare the incoming AC voltage from the mains with a reference voltage.

5.3.1 Under voltage protection control circuit

This circuit was made to monitor the input voltage from the mains and produce a HIGH at its output when the input at the non-inverting input (+) is higher than the voltage at the inverting input terminal (-) that is connected to the utility mains and this will only occur when the voltage from the utility mains is below 140V.

When the input voltage from the utility mains is below 140V, the comparator compares the incoming voltage with the Vref and produces a HIGH at its output terminal. The HIGH produced by the comparator signals the microcontroller of a low input voltage from the utility mains. The microcontroller then cuts off the flow of power through mode I by initiating the transfer of power to the load from the standby battery which is mode II to avoid damages caused by low voltages or under voltage.

5.3.2 Over voltage protection control circuit

The same operational principle of the under voltage protection unit applies here, the design is such that the differential output of the comparator will go high when the voltage at the non-inverting

input (+) is higher than the voltage at the inverting input (-) mains and this will only occur when the voltage from the utility mains is above 260V. This time around, Pin2 of the comparator is the inverting input; pin 3 is the non-inverting input while pin 1 is the differential output.

When the input voltage from the utility mains is above 260V, the comparator compares the incoming voltage with the Vref and produces a HIGH at its output pin to the microcontroller and the entire system is immediately switched to mode II to protect the load from an over voltage.

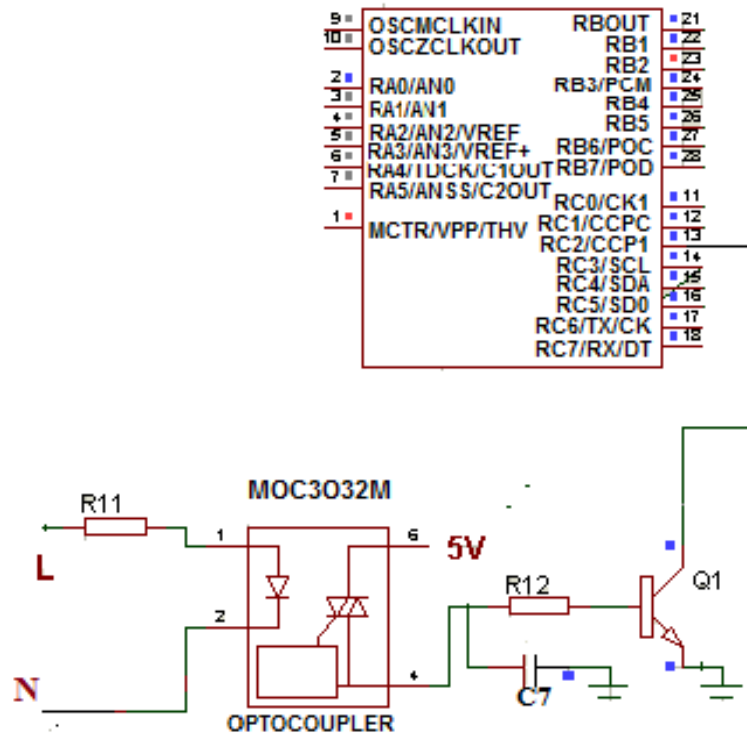

Fig. 10. Circuit diagram of the automatic control switch interfacing the microcontroller

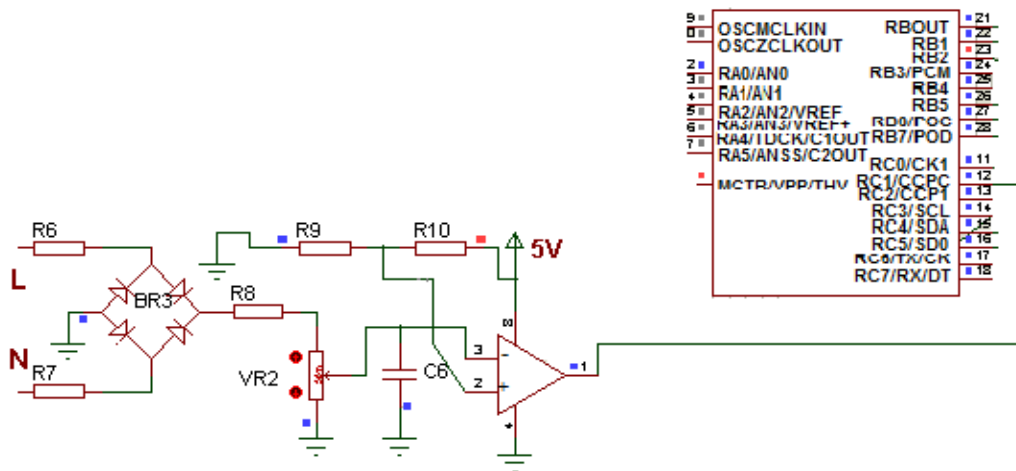

Fig. 11. Diagram of over voltage protection circuit

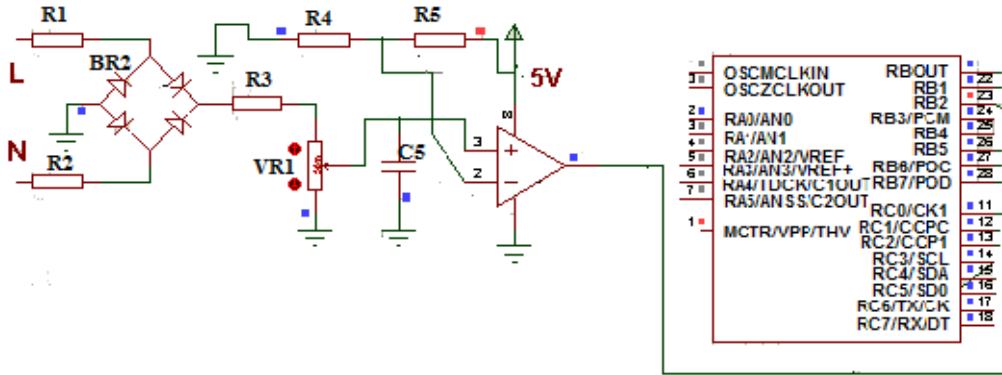

Fig. 12. Diagram of over voltage protection circuit

6. THE OUTPUT UNIT OF THE SYSTEM

The output unit is made of the double winding center-tapped transformer and the alarm system.

6.1 The Double Winding Centre-Tap Transformer (T_2, T_3)

The fabricated device (UPSz) is complex because it has two converters with two separate voltage sources controlled by one microcontroller. Hence the output of each DC-AC converters also differs from each other. This poses a problem of not being able to tie the two voltages together. In respect to this, a double winding transformer with center tap or a center tapped multiple winding transformer was used and the transformer is a step up transformer.

This type of transformer has two primaries and two secondary cascaded together as one with each having separate turn ratio or windings. It is more like two transformers in one, such that one primary and one secondary can be assigned as the transformer to a particular voltage source and the other connected to another voltage source but their various outputs are the same and can be tied together. In the case of this study, the transformers are called T_2 and T_3 in which T_2 is connected to the DC-AC converter (K11) output, meaning it functions during mode I alone and T_3 is connected to the output of the standby DC-AC converter (k22) (functions at mode II alone). The output voltage of the transformer is 220V.

The transformer ratio (A) for both T_2 and T_3 was obtained as thus:

If A_2 is the transformer ratio of T_2 , therefore;

$$A_2 = N_2 / N_1 = V_{ii} / V_i \quad (17)$$

Where $V_{ii} = 220V$ (output voltage of the transformer T_2)

$V_i = 97.29V$ (input voltage of the transformer T_2 , which is also the output voltage of the line DC-AC converter)

Therefore,

$$A_2 = 220V / 97.29 = 2.26$$

thus, V_7 in Fig. 1 can be obtained as;

$$V_7 = A_2 V_4 = 2.26 \times 97.29 = 220V. \quad (18)$$

A_3 is the transformer ratio for T_3 , therefore;

$$A_3 = N_2 / N_1 = V_{ii} / V_i \quad (19)$$

Where $V_{ii} = 220V$ (output voltage of the transformer T_3)

$V_i = 5.895V$ (input voltage of the transformer T_3 , which is also the output of the standby DC-AC converter)

Therefore,

$$A_3 = 220V / 5.895 = 37.32$$

$$V_7 = A_3 V_6 = 37.32 \times 5.895 = 220V$$

The transformers are centre tapped (both T_2 and T_3) for voltage regulation purpose.

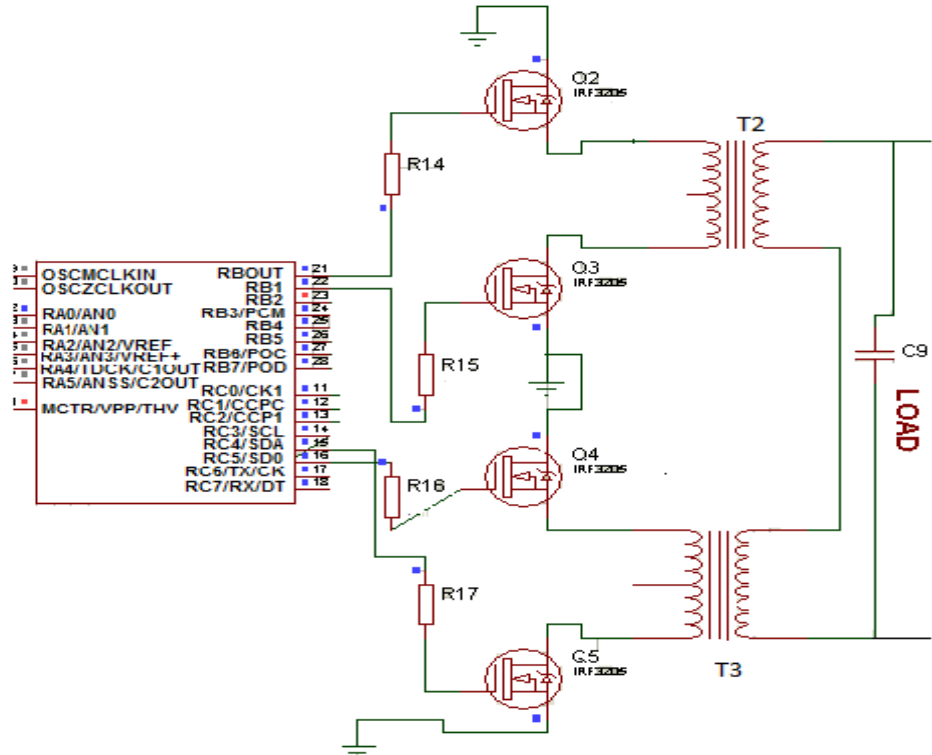

Fig. 13. Diagram of the two DC-AC converters interfacing the microcontroller and the transformer

Since the battery backup time is known, the output power and output current from the battery to the load during mode II can also be gotten as;

$$\text{Battery power} = Pf \times \text{battery voltage} \times Ah \quad [13](20)$$

Where Pf = power factor = 0.8 (as specified on the name plate), Battery voltage = 12V, Ampere per hr = 50Ah

Therefore, battery power = $0.8 \times 12 \times 50 = 480W$

Since the power flowing from the battery to the standby DC-AC converter is obtained to be 480 W. The output power from the standby DC-AC converter can also be deduced as:

$$\text{Input Power} \times pf \text{ of the standby DC-AC converter} = \text{Power output} \quad [14] (21)$$

$$P_{in} \times pf = P_{out}$$

$P_{in} = 480W$ (power of the battery entering the standby DC-AC converter), $Pf = 0.98$ (as calculated in earlier for the standby DC-AC converter)

Thus;

$$\text{Power output } (P_{out}) = 480 \times 0.98 = 470.4W$$

The output current (I_{out}) can be gotten as

$$I_{out} = P_{out} / V_{out} \quad (22)$$

Where

$$V_{out} = V_6 = 5.895V, P_{out} = 470.4W$$

$$I_{out} = 470.4W / 5.895V = 92.24A$$

Where $I_{out} = I_6$

The efficiency of the associated transformer T_3 is given as 95-98% on full load. This is stated as specified by the manufacturer. In this work, a worse case efficiency of 95% was assumed.

Therefore the output power from the transformer can be gotten as:

$$\text{Power output from } T_3 = \text{Power input to } T_3 \times \text{efficiency of } T_3 \quad (23)$$

where, $P_{inT3} = P_{out}$ of the standby DC-AC converter = 470.4W, efficiency of $T_3 = 0.95$

$$P_{outT3} = 470.4 \times 0.9 = \mathbf{446.88W}$$

The output current I_7 can be calculated as

$$P_{outT3} = I_7 \times V_7 \times Pf \quad [14] (24)$$

Or

$$I_7 = P_{outT3} / V_7 \times Pf \quad (25)$$

Where $P_{outT3} = 446.88W$ as obtained earlier, $V_7 = 220V$ (Stepped up output of T_3), $pf = 0.95$ (transformer efficiency)

$$I_7 = \frac{446.88}{220 \times 0.95}$$

$$I_7 = \mathbf{2.03A \approx 2A}$$

This current is the maximum current drawn by the load from the UPSz to maintain its recommended efficiency of **0.98** (targeted efficiency). Since we know the power input and the power output of the UPSz, the power loss of the device can then be obtained.

$$\text{Power loss} = \text{power input } (P_{in}) - \text{power output } (P_{out}). \quad (26)$$

Where

$$(P_{in}) = 480W, (P_{out}). = 446.88W$$

$$\text{Power loss} = 480 - 446.88 = 33.12W$$

$$\text{Power loss} = \mathbf{33.12W}$$

This loss is as a result of the switching processes performed by the semiconductor devices in the UPSz.

6.2 Alarm Circuit

The aim of the alarm unit is to signal the user about the interruption of power from the utility mains and also bringing to the attention of the user to the fact that the UPSz is operating on battery mode or Mode II. In the design of this circuit, the pin14 of the microcontroller is connected to the alarm circuit. From the program in the microcontroller, pin14 remains LOW at no signal detection. As the device (UPSz) switches from mode I to mode II, a signal is detected and a HIGH appears across pin14.

It is such that the program in the microcontroller stimulates for the production of the signal to the transistor which switches the buzzer ON and OFF continuously to produce a beeping sound at equal interval. The beeping sound continues to occur until the mode I is restored and the pin14 of the microcontroller returns to its LOW state or the device completely shuts down.

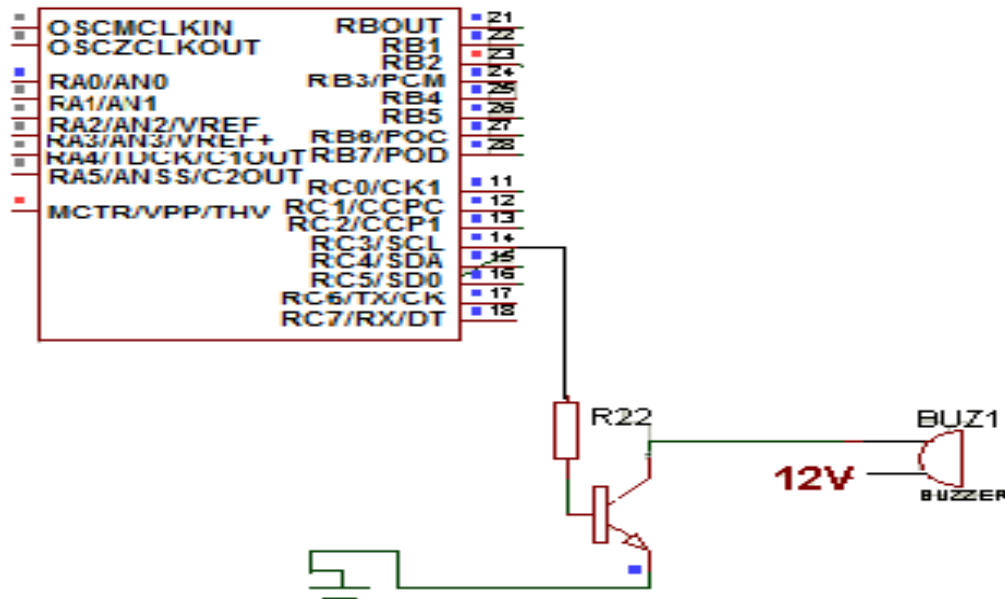

Fig. 14. Diagram of the UPSz alarm unit

7. PACKAGING

The complete unit was housed in a metallic black casing. Battery terminals for positive and negative, power switch, handle, LED bulbs and output meter were fixed in their allotted slots and connected to their respective points on the circuit.

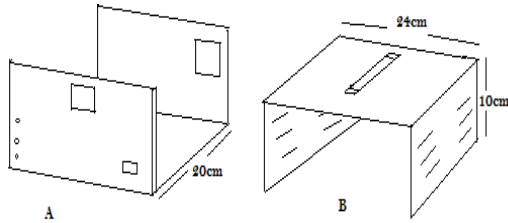

Fig. 15. Sketch of the casing

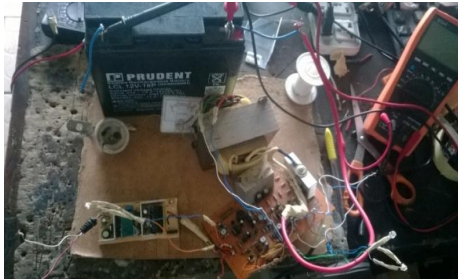

Fig. 16. Overview of the UPSz circuitry



Fig. 17. Packaging of the UPSz into a casing

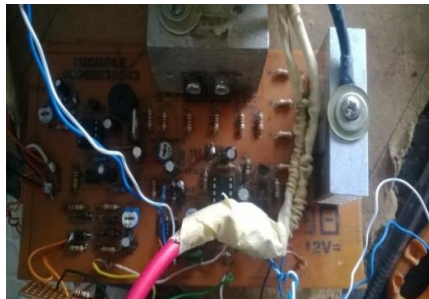

Fig. 18. Picture of the motherboard of the UPSz



Fig. 19. The Uninterruptible Power Stabilizer



Fig. 20. Side view of the UPSz

8. EXPERIMENT AND TESTING

The UPSz was designed to handle voltage fluctuation and irregularities from a range of 140V to 260V to produce a steady 220V output at all time. In order to verify the working condition and capability of the UPSz during input voltage change and variations, a **VARIAC** was introduced to the input terminal of the UPSz.

Testing involved checking the output voltage and current of the UPSz when various input voltage level were introduced into the UPSz with loads ranging from 60W, 100W, 200W, 300W and 400W connected to it. In addition, an offline bypass UPS of 500VA, 220V ratings was also tested using the variac and the results gotten were compared with the constructed device. Testing and comparison were also made on mode II for the UPSz and the offline UPS and the results obtained were compared and graphically illustrated.

9. GRAPHICAL RESULTS

The graphical results are the representation of the working ability and performance of both devices when handling various voltage levels.

10. DISCUSSION OF THE GRAPHS

Voltage stabilization is a process of feeding or delivering constant voltage or current to electrical load and protects them from damages due to voltage fluctuation. It is such that the output voltage and current remains at some defined window limit. For electronic devices and gadgets, the save margin or window lies between 220V – 180V as proper guarantee of maximum functionality and protection against over voltage and under voltage cannot be assured above or below this margin except for industrial purpose [15]. In Nigeria, the national electric grid power supply for home use fluctuates at 180V to 220V except unprecedentedly events occurs during transmission leading to voltage fluctuation. Basically, for a maximum load of 400W, the output current was 2.07A and for an input voltage of 260V and 2.19A for an input voltage of 140V. That means that the change in the output current from 140V- 260V is about 0.12A (2.19A-2.07A)

$$\text{From the equation } P = I \times V \quad (27)$$

Where P = power (W), I = current (A) and V= voltage (V), it can be seen that current is inversely proportional to voltage and directly proportional to power. This implies that as power increases, current increases and voltage decreases. Therefore, a low input voltage would result to a low output voltage with high output current and a high input voltage would result to a high output voltage with low current. Voltage stabilization would result to the production of a steady/constant output voltage and current even at a high or low input voltage.

In Fig. 21; it can be seen that at a high input voltage of 260V, the UPSz delivered a current of 0.46A to a load of 60 W and 2.07A to a load of 400 W whereas the offline UPS delivered a current of 0.23A to a load of 60 W and 1.55A to a load of 400W. As the input voltage from the utility mains is reduced to 240V as seen in Fig. 22, the UPSz delivered a current of 0.46A to a load of 60 W and 2.07A to a load of 400W while the offline UPS delivered a current of 0.24A to a load of 60W and 1.60A to a load of 400W. A further reduction in the input voltage from 240V to 220V as shown in Fig. 23 revealed that the UPSz was able to deliver a current of 0.47A to a load of 60 W and 2.08A to a load of 400 W while the offline UPS delivered a current of 0.26A to a load of 60

W and 1.91A to a load of 400 W. From the above observation, it can be seen that as the input voltage reduces, the output current of the UPSz remains almost the same indicating that voltage stabilization occurred but the output current of the offline UPS increases gradually with decrease in the input voltage.

Also in Fig. 23, Fig. 24 and Fig. 25; it can be seen that at a normal voltage supply level of 180V to 220V, the UPSz supplied current of 0.49A – 0.47A to a load of 60W and 2.10A – 2.08A to a load of 400W while the offline UPS supplied a current of 0.39A - 0.26A to a load of 60W and 2.03A – 1.91A to a load of 400W.

This means that the interval change in the output current of the offline UPS between 180V – 220V for a load of 60W is about 0.31A (0.39A – 0.26A) and for a load of 400W is 0.39A (2.30A – 1.91A) while that of the UPSz from 180V – 220V for a load of 60W is 0.02A (0.49A – 0.47A) and for a load of 400W is 0.02A (2.10A – 2.08A). This implies that a change of about 0.02A occurred at the output current of the UPSz during a normal supply voltage of 180V to 220V unlike the offline UPS which is about 0.39A. Therefore, indicating that stabilization of voltage/current level was made possible by the UPSz.

As earlier stated, the offline UPS offers little or no protection against voltage fluctuation, as can be seen from the data generated from the test and presented in Fig. 25 to Fig. 27. From the figures, the voltage increases as the current exponentially decreases. Cases with fluctuating power supply would experience gadget and electronic device failure or damages if the offline UPS is constantly used in such cases.

In Fig. 28, which is the graphical representation of the data obtained from mode II, it can be evidently seen that the offline UPS and the UPSz operates at the same efficiency until the battery voltage begins to drop. From the graph, it was observed that there was a sharp increase in the output current of the offline UPS as the voltage of the battery drops to 11.2V and a sequential continuous increase in the output current as the voltage of the battery drops further. Clearly the UPSz stabilizes and delivers 220V as its output voltage even as the DC voltage of the battery drops whereas the offline produced lesser output voltage with higher current as the voltage of the battery drops.

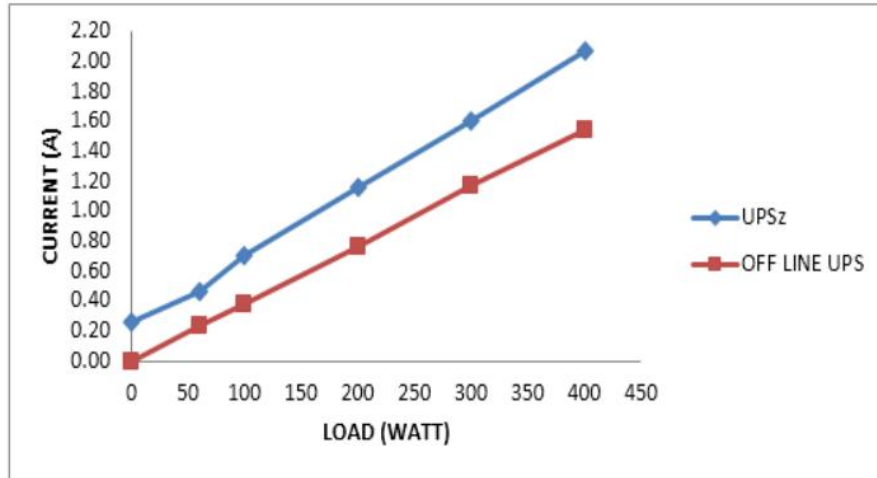

Fig21: A graph of load against current for both the UPSz and the offline UPS at 260V AC input voltage.

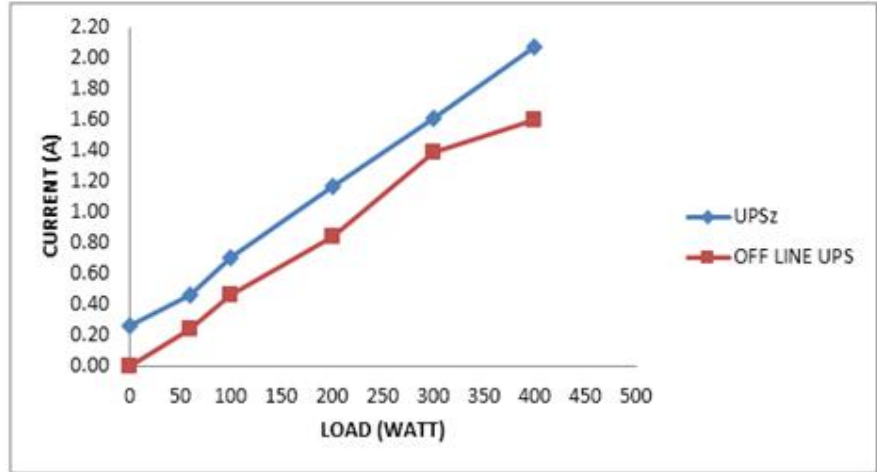

Fig 22 A graph of load against current for both the UPSz and the offline UPS at 240V AC input voltage.

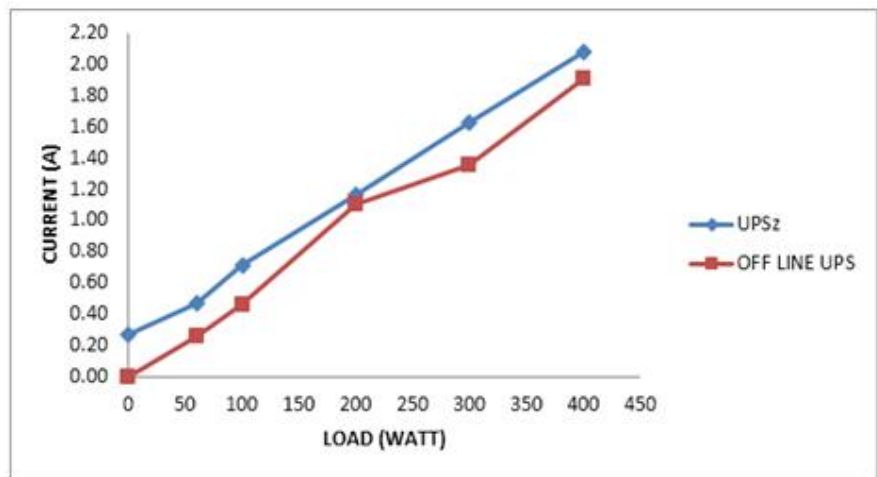

Fig 23 A graph of load against current for both the UPSz and the offline UPS at 220V AC input voltage.

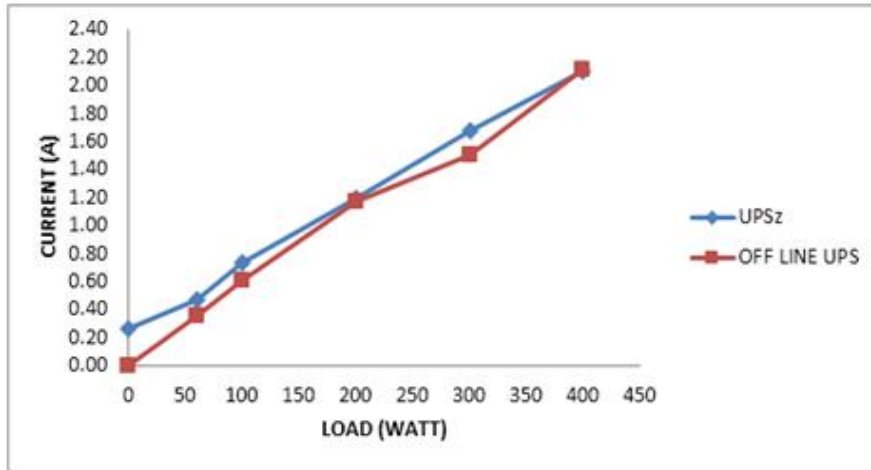

Fig 24 A graph of load against current for both the UPSz and the offline UPS at 200V AC input voltage.

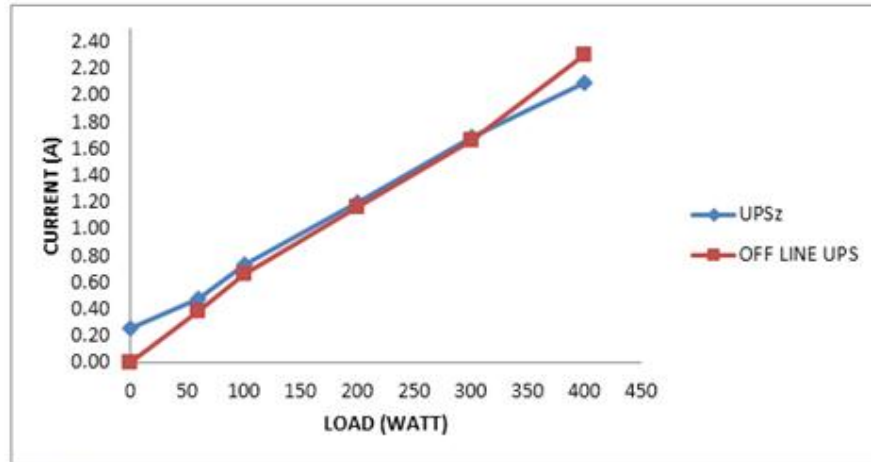

Fig 25 A graph of load against current for both the UPSz and the offline UPS at 180V AC input voltage.

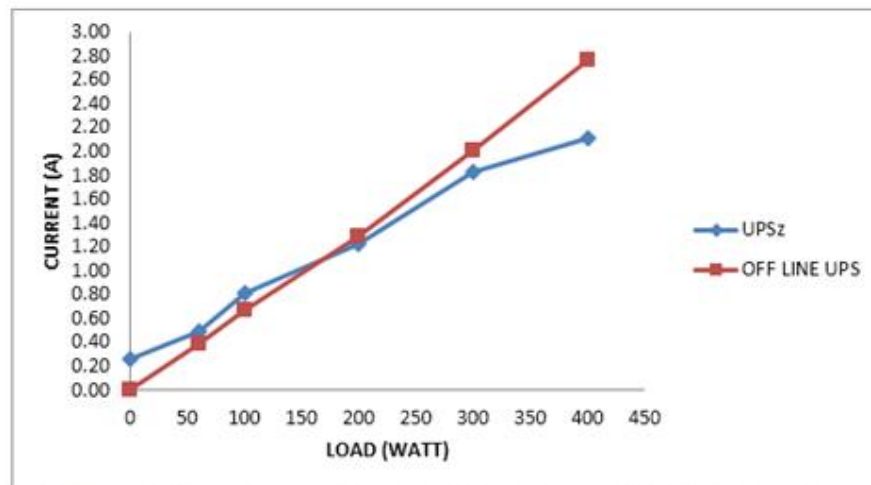

Fig 26 A graph of load against current for both the UPSz and the offline UPS at 160V AC input voltage

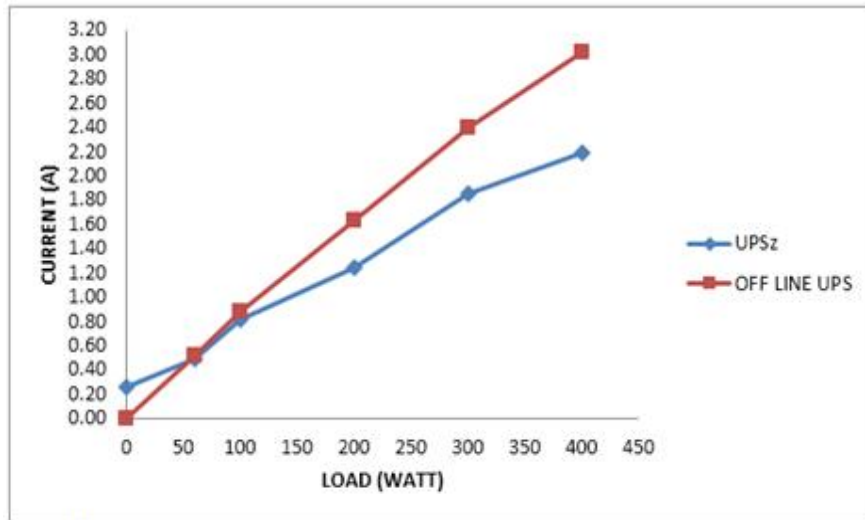

Fig 27 A graph of load against current for both the UPSz and the offline UPS at 140V AC input voltage.

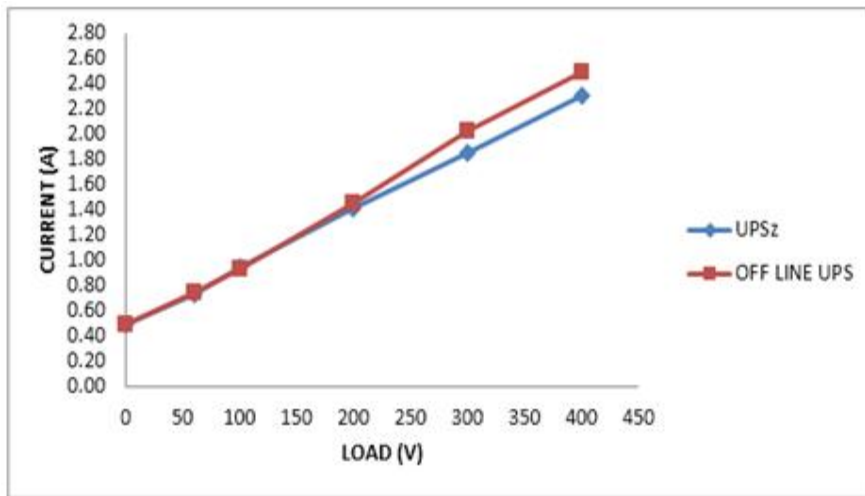

Fig 28 A graph of load against current for both the UPSz and the offline UPS during mode II

The discharge duration of the battery with respect to load power consumption was calculated using the equation below.

$$\text{Discharge duration} = \frac{\text{Battery voltage} \times \text{Ah (ampere per hour)} \times \text{Power factor}}{\text{Total Load}} \quad [16] (28)$$

Where battery voltage = 12V, Ampere per hour = 50Ah, Loads = 60W, 100W, 200W, 300W, 400W

$$D_d = (12 \times 50 \times 0.8) / 60 = 8.0 \text{ hrs}$$

$$D_d = (12 \times 50 \times 0.8) / 100 = 4.8 \text{ hrs}$$

$$D_d = (12 \times 50 \times 0.8) / 200 = 2.4 \text{ hrs}$$

$$D_d = (12 \times 50 \times 0.8) / 300 = 1.6 \text{ hrs}$$

$$D_d = (12 \times 50 \times 0.8) / 400 = 1.2 \text{ hrs}$$

The figures obtained in Table 2 are not forever constant as subsequent and continuous use of the battery can result to less discharge duration of the battery. It is well known that the higher and bigger the battery capacity, the longer the discharge duration.

Table 2. Discharge durations of the UPSz battery with load

Load (Watts)	Duration (hrs)
60	8.0
100	4.8
200	2.4
300	1.6
400	1.2

11. CONCLUSION

The UPSz has shown to be a better than the offline UPS. This is because it has the ability to stabilize fluctuating voltages thereby providing surge protection against over voltages and under voltages. The application of PWM technique in the UPSz provided a higher margin of voltage stabilization. This margin therefore allows for a longer fluctuation range for the load to be fed without reverting to battery mode at any short disturbance. This way, there will be less use of the battery thereby leading to a longer battery life.

The supply of continuous power to the load in the absence of electricity from the utility mains was made possible by the battery. Additionally, in monitoring voltage levels, the UPSz has shown to have a wide range of voltage fluctuation tolerance of about $\pm 40V$ to the usual supply voltage from the utility mains of 180V – 220V within which the UPSz performed better than the offline UPS in delivering current to loads.

12. LIMITATION

It has a slow charging rate due to the nature of the charging unit introduced.

It is only limited to home and office use basically for computers, televisions and other light household electronics.

It does not produces a pure sin wave output voltage waveform based on the nature of the power modules (MOSFET) used and its configuration

13. RECOMMENDATION

Increasing the rate at which the battery of the UPSz charges is highly important. It is recommended that a stronger and faster charging system should be incorporated to reduce the charging time at which the battery completely gets charged. This section is highly important because the working condition of the UPSz depends on the battery life.

Increasing the power rating of the UPSz is also important so as to power more load conveniently. This can be done by increasing the ratings of power switching devices, the battery and the transformer.

It is well known that the higher and bigger the battery capacity, the longer the discharge duration. Therefore to increase the discharge duration of the UPSz, a strong and higher capacity battery should be introduced to prolong the use of the UPSz during DC mode.

Switching should be done using silicon controlled rectifiers (SCRs) as against the use of MOSFETs. This is because they have a wider range of switching speed and a better current/voltage handling capability. When used as switches in a DC-AC converter, they tend to produce a steadier/constant output voltage and current thereby eliminating the use of the centre-tapped multiple winding transformer at the output.

14. COSTING

Materials needed in the fabrication of the UPSz are tabulated in Table 3.

Table 3. Materials used and their cost

S/N	Components	Description	QTY	Unit cost (₦)	Total cost (₦)
1	Transformer	220V/12V	1	500	500
2	D/W transformer	220V	1	700	700
3	Diode	1N4001	10	10	100
4	Capacitor	10 μ F/25	5	20	100
5	"	47 μ F /440V	5	20	100
6	"	100 μ F /25V	5	50	250
7	"	33 μ F /25V	2	30	60
8	Inductor	680 μ H	2	50	100
9	Bridge Rectifier	-	3	50	150
10	LED	1.8V	3	10	30
11	Crystal oscillator	8MHZ	1	50	50
12	Resistor	100K Ω	5	50	250
13	"	10K Ω	4	20	80

S/N	Components	Description	QTY	Unit cost (₦)	Total cost (₦)
14	"	1.5KΩ	3	30	90
15	"	1KΩ	2	10	20
16	"	10KΩ (VARIABLE RESISTOR)	3	20	60
17	Power mosfets	IRF3205 N- CHANNEL	4	150	600
18	Transistor	NPNC1818	2	50	100
19	OP-AMP	LM358	2	100	200
20	Microcontroller	PIC16F876A	1	1200	1200
21	Voltage regulator	7805/50K	1	50	50
22	Optocoupler	PC817	1	100	100
23	Buzzer	5V (ELM)	1	100	100
24	Rechargeable battery	DC	1	2000	2000
25	Veroboard	DOT	1	100	100
26	"	PLAIN	1	500	500
27	Analog voltmeter	INDICATOR	1	50	50
28	Power cord	-	1	100	100
29	Connector wires	-	-	-	1000
30	Socket	WALL	1	150	150
31	Casing	METAL	1	500	500
32	soldering LED	ROLE	1	350	350
33	Man hour	120HOUR	@	250 per hr	-
34	Miscellaneous	-	-	5000	5000
35	FAN	SMALL	1	120	120
Total					₦ 14,410

COMPETING INTERESTS

Authors have declared that no competing interests exist.

REFERENCES

1. Thomas E. Electricity and electronics, Glencoe McGraw hill, London. 2011;280-301.
2. Dharal D. Boosting power supply efficiency for desktop computers, Power Electronics Technology. 2012;5:14-23.
3. Mori M, Jensterle M, Tilen M. Life-cycle assessment of a hydrogen based uninterrupted power supply system using renewable energy. International J Life Cycle Assess. 2014;1:1-13.
4. Watkins SS. History and development of switch mode power supplies. International Journal of Engineering and Advance Technology. 2014;2:98-135.
5. Lee FC, Liu KH. Resonant switches; a unified approach to increases performance of switching converters, proc. IEEE Int'l Telecommunication Energy Conference (INTELEC). 2011;334-341.
6. Belady BH. Design and implementation of a 3 input microcontroller based voltage selector with feedback system, Computer Engineering and Intelligent System. 2014; 3:106-118.
7. Kassakin OW. Design and construction of a solar powered based UPS for lighting system. International Journal of Engineering, Sciences and Research Technology. 2011;13:14-31.
8. Malvino TB, Kiver OR. Design and construction of 1KW (1000VA) power inverter. Innovative Systems Design and Engineering. 2007;5:222-235.
9. Mohan C, Molnar R. Metric to characterize data center and IT equipment energy use, Proc. Digital Power Forum, Dallas. 1998; 165-182.
10. Kiruthika C, Ambika T, Seyezhai R. Simulation of cascaded multi-level Inverter using hybrid PWM technique. International Journal of Systems, Algorithms and Applications. 2011;1:18-21.
11. Kumar KO, Omar KS. Dynamic voltage stabilizer. Electrical Power Quality and Utilization. 2013;19:17-23.

12. Solomon FA, Kwaja T, Ehis JJ. Fundamentals in applied electronic. Jos University Press Ltd, Jos, Nigeria. 2014;120-132.
13. Bose BK. Power electronics and motor drives. Academics Press, Burlington, M.A, USA. 2006;917.
14. Dahnono VB, Tabisz WA, Pouchet J. Zero-voltage switching multi-resonant technique; a novel approach to improve performance of high frequency quasi-resonant converters, IEEE Power Electronics Specialist Conference (PESC). 2011;9-21.
15. Zack GO. Quality of electricity supply and management of network losses. IEEE International Conference on Harmonics and Quality of Power. 2013;73-81.
16. Patrick O, Tolulope O, Anthony MC. Design and implementation of 1KVA uninterruptible power supply. International Journal of Engineering Sciences and Research Technology. 2014;3:962-971.

APPENDIX

The complete circuit diagram of the uninterruptible power stabilizer.

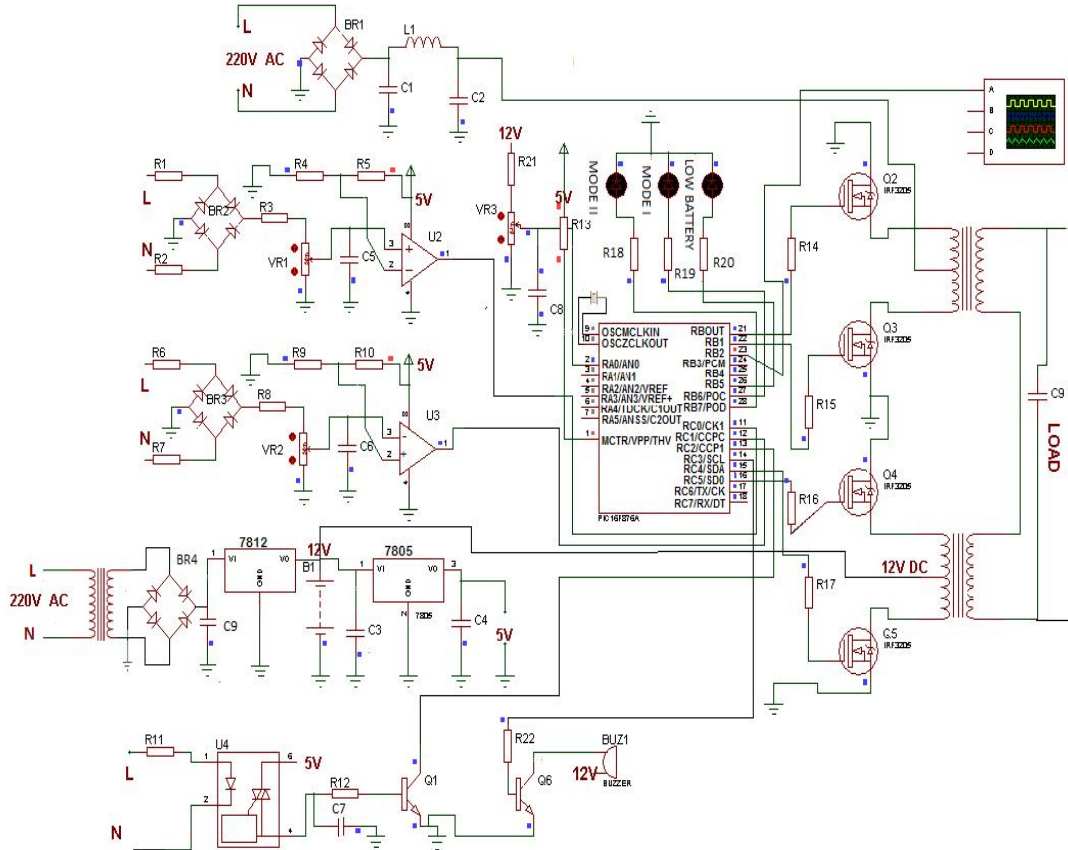

© 2017 Sunny et al.; This is an Open Access article distributed under the terms of the Creative Commons Attribution License (<http://creativecommons.org/licenses/by/4.0>), which permits unrestricted use, distribution, and reproduction in any medium, provided the original work is properly cited.

Peer-review history:
 The peer review history for this paper can be accessed here:
<http://sciencedomain.org/review-history/18189>