



## Mathematical Modeling of Sex Related Differences in the Sensitivity of the Sweating Heat Responses to Change in Body Temperature

Saraswati Acharya<sup>1\*</sup>, D. B. Gurung<sup>1</sup> and V. P. Saxena<sup>2</sup>

<sup>1</sup>Department of Natural Sciences (Mathematics), Kathmandu University, Nepal.

<sup>2</sup>Sagar Institute of Research and Technology, Bhopal, India.

### Article Information

DOI: 10.9734/BJMCS/2016/20068

#### Editor(s):

(1) Ioannis Konstantaras, University of Macedonia, Thessaloniki, Greece.

#### Reviewers:

(1) Anonymous, C.R.M.E.F, Morocco.

(2) Francisco Bulnes, Tecnológico de Estudios Superiores de Chalco, Mexico.

Complete Peer review History: <http://sciencedomain.org/review-history/11985>

Original Research Article

Received: 09 July 2015

Accepted: 26 August 2015

Published: 26 October 2015

### Abstract

The present study describes variational finite element method for one dimensional heat transfer model based on time independent sweating responses. The Penne's model with mixed boundary condition is considered for describing comparative temperature profiles of human females luteal and follicular phases of menstrual cycle and temperature profiles of males. Human dermal region under consideration is divided into six parts along with fatty and muscle parts of subcutaneous tissue (ST). Sweat rate of females is lower as compared to males owing to a lower density of sweat glands and different hormone patterns. Sweating is considered as a heat loss within the body. The physical and physiological parameters in each layer that affect the heat regulations in human body are taken as a function of position. The steady state analysis delineates that during the luteal phase females tissue temperature is higher as compared to follicular phase of the menstrual cycle. These temperatures are less as compared to males body temperatures when atmospheric temperature  $T_{\infty}$  falls below the body core temperature. But the tissue temperature of females luteal phase is slightly higher as compared to males when  $T_{\infty}$  exceeds the body core temperature. The result may be useful to study thermal behavior of the biological system.

*Keywords:* Finite element method; Penne's model; dermal region; luteal phase; follicular phase.

\*Corresponding author: E-mail: [saraswati.acharya@ku.edu.np](mailto:saraswati.acharya@ku.edu.np), [saraswati\\_acharya2000@yahoo.com](mailto:saraswati_acharya2000@yahoo.com);

## 1 Introduction

The body is basically an isothermal system as the core temperature is maintained 37°C over a wide range of environment conditions and during exercise. Analysis on heat transfer of biological bodies consists of determination of system parameters, such as thermal conductivity, blood perfusion, and metabolic heat generation. Sweating is absolutely essential to survive in a hot environment. The purpose of sweating is to facilitate heat removal from the skin when convective and radioactive heat transfers are inadequate. In humans, increasing the sweating rate is the main way of dissipating excess heat from the body during exercise in a warm environment, since the evaporation of sweat is the only way to lose heat when the ambient temperature is higher than the skin temperature.

The dimorphism in body structure, limb proportions, surface area, insulating muscle and fat mass, thickness distribution between males and females, results in females maintaining a lower skin blood flow and, consequently, lower skin temperatures.

Body temperature is sensitive to many hormones; females have a temperature rhythm that varies within the menstrual cycle. The changing rate of sex hormone release during the menstrual cycle and ovulation periods modifies thermoregulation in females. Females' follicular phase releases estrogen hormone which cools the body temperature before ovulation. Likewise, luteal phase produces progesterone hormone, it warms the body temperature after ovulation and until menstruation [1]. The core temperature is around ~0.3-0.6°C higher during the luteal phase relative to the follicular phase [2]. The rise in plasma concentration of progesterone during the luteal phase of menstrual cycle results in the increment of females' body temperatures comparison with the follicular phase [3].

The body mass represents the capacity of the body to store heat. The amount of body surface area exposes to the external environment, determine the heat exchange between the skin and ambient temperature such as high body surface area and body mass generally associated with higher skin temperature. In general, females have less body mass and less body surface area compared to males. Larger surface areas allow more molecules to leave the liquid than smaller one, and therefore sweat occurs more rapidly in males. Metabolic energy expenditure is proportional to body mass. Lower rate of metabolic heat production elicit a lower sweat rate in females. So the body mass and surface area is the physical parameter associated with lower sweat rate in females.

The physiological parameter associated with lower sweat rate in females is due to less thermal sensitivity of the response and delay sweating. Menstrual cycle is one of the major physiological differences in temperature regulation of females than males. Several authors reported that females have a relatively lower sweat rate in heat during both rest and exercise [4].

Nodal et al. [5] conducted a study on the importance of the skin temperature in the regulation of the sweating. They concluded that at a constant skin temperature, sweating rate is proportional to core temperature. Conversely at a constant core temperature, sweating is proportional to skin temperature. Also the local sweating depends on the local skin temperature of a given combination of core and mean skin temperature.

Sweating is one of the effective thermoregulatory processes when the body is in hot condition of heat strain caused by hot ambient conditions or a high metabolic rate. The sweat rate is calculated as a weighed mean value of the body core and skin temperature. The plausible equation for the sweat rate for males is [6].

$$E = 8.47 \times 10^{-5} \{ (0.1 \times T_{sk} + 0.9 \times T_b) - 36.6 \text{ } ^\circ\text{C} \} \text{ (kg/m}^2\text{/sec)} \quad (1)$$

Where,  $T_{sk} = T_0$  (Initial nodal Temperature),  $T_b = 37^\circ$  (Body Core Temperature).

The sweat rate in females is smaller compared to males due to the lower density of sweat gland and hormonal pattern in females. So, it is reasonable to accept the value 0.7 instead of 0.9 in equation (1) for females [6].

Research on thermoregulation in human is extensive and has been limited to a homogeneous population consisting mainly of males. Earlier models have not attempted to delineate the differences in thermoregulation between males and females. So the present study focuses on mathematical model of the body temperatures in males and females due to sweating responses for thermal sensitivity. The sweating responses in females are observed during menstrual cycle in luteal and follicular phase.

## 2 Bio-heat Equation and Boundary Conditions of the Model

The governing differential equation that represents the bio-heat transfer in the human skin which is used to model the thermal behavior of skin tissue is given by [7].

$$\rho c \frac{\partial T}{\partial t} = \nabla \cdot (K \nabla T) + \rho_b \omega_b c_b (T_a - T) + S \quad (2)$$

where  $\rho$  ( $kg/m^3$ ) is the tissue density,  $c$  ( $J/kg^\circ C$ ) is the specific heat,  $T$  ( $^\circ C$ ) is the local tissue temperature,  $t$  is the time,  $K$  ( $w/m^\circ C$ ) is the tissue thermal conductivity,  $\omega_b$  ( $m^3/s/m^3$ ) is the blood perfusion,  $\rho_b$  ( $kg/m^3$ ) is the density of blood,  $c_b$  ( $J/kg^\circ C$ ) is the specific heat of blood,  $T_a$  is the arterial blood temperature,  $S$  ( $w/m^3$ ) is the metabolic heat generation in the body,  $M$  ( $w/m^3^\circ C$ ) =  $\rho_b \omega_b c_b$ .

If the outer surface of the body is exposed to the environment then the heat loss caused via convection, radiation and sweat evaporation. So mixed boundary condition under study is given by:

$$\Gamma_1 - K \frac{\partial T}{\partial \eta} \Big|_{at \ skin \ surface} = h(T - T_\infty) + \sigma \varepsilon (T^4 - T_\infty^4) + LE \quad (3)$$

where,  $h$  ( $w/m^2^\circ C$ ) represents heat transfer coefficient between skin and environment,  $T_\infty$  ( $^\circ C$ ) is the atmospheric temperature,  $\sigma$  ( $5.67 \times 10^{-8} w/m^2^\circ C^4$ ) is the Stefan Boltzmann constant,  $\varepsilon$  is emissivity of the skin surface emissivity of the surface,  $L$  ( $J/kg$ ) is latent heat of evaporation and is  $E$  ( $kg/m^2/sec$ ) evaporative heat loss between skin surface and environment.

Also the human body maintains its core temperature at a uniform temperature at  $37^\circ C$ . Therefore, the boundary condition at the inner boundary for one dimensional case is taken as:

$$\Gamma_2: T_b = 37^\circ C \quad (4)$$

Where,  $T_b$  is the body core temperature.

The nonlinear radiation term in the boundary condition (3) is treated by using iterative procedure as follows [10]

$$-K \frac{\partial T_1}{\partial \eta} \Big|_{at \ skin \ surface} = [h + \sigma \varepsilon (T_1 + T_\infty)(T_1^2 + T_\infty^2)](T_1 - T_\infty) + LE \quad (5)$$

$$-K \frac{\partial T_1^n}{\partial \eta} \Big|_{at \ skin \ surface} = h_{cr}(T_1^n - T_\infty) + LE \quad (6)$$

where,

$$h_{cr} = h + \sigma \varepsilon (T_1^{n-1} + T_\infty)((T_1^{n-1})^2 + T_\infty^2)$$

$$h_{cr} = h_{convection} + h_{radiation}$$

where  $T_1^n$  are temperature sequences for  $n = 1, 2, 3, \dots$  and  $T_1^0$  represents an initial guess of temperature. The iteration is completed when the convergent condition is satisfied  $\|T_1^n - T_1^{n-1}\| < \delta$ , where  $\delta$  is iteration tolerance.

### 3 Skin Geometry and Assumptions

For the purpose of modeling, one dimensional skin layers are divided into six regions. The thickness of stratum corneum, stratum germinativum, papillary region, reticular region, fatty and muscle layers of subcutaneous tissue (ST) have been considered as  $l_1, l_2 - l_1, l_3 - l_2, l_4 - l_3, l_5 - l_4, l_6 - l_5$  respectively and  $T_0, T_1, T_2, T_3, T_4, T_5$  and  $T_6 = T_b$  are the nodal temperatures at a distances  $x = 0, x = l_1, x = l_2, x = l_3, x = l_4, x = l_5$  and  $x = l_6$ . Temperatures  $T^{(i)}, i=1, 2, 3, 4, 5, 6$  be the linear shape function in each layer depending on the thickness of layers.

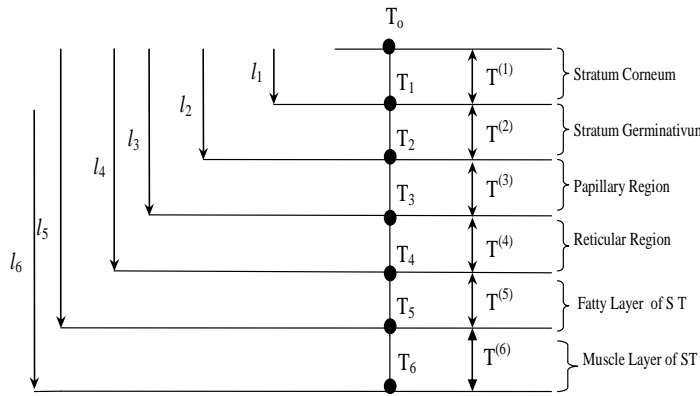

Fig. 1. Schematic diagram of human skin layers

The anatomical structure of human dermal part makes it reasonable to consider  $M$  and  $S$  zero in stratum corneum. In the model, the thermal conductivity in the layers of dermal part is considered as constant. All the assumptions for parameters in the layers of dermal part can be summed up as:

Table 1. Assumptions for the parameters in the layers of dermal part

Quantity	I	T	$T_a$	K	M	S
Outer boundary		$T_0$	-	-	-	-
Stratum corneum ( $0 \leq x \leq l_1$ )	$I_0$	$T^{(1)} = T_0 + \frac{T_1 - T_0}{l_1} x$	$T_a^{(1)} = 0$	$K^{(1)}$	$M^{(1)} = 0$	$S^{(1)} = 0$
Stratum germinativum ( $l_1 \leq x \leq l_2$ )	$I_2$	$T^{(2)} = \frac{l_2 T_1 - l_1 T_2}{l_2 - l_1} + \frac{T_2 - T_1}{l_2 - l_1} x$	$T_a^{(2)} = 0$	$K^{(2)}$	$M^{(2)} = 0$	$S^{(2)} = \left(\frac{x - l_1}{l_6 - l_1}\right) S$
Papillary region ( $l_2 \leq x \leq l_3$ )	$I_3$	$T^{(3)} = \frac{l_3 T_2 - l_2 T_3}{l_3 - l_2} + \frac{T_3 - T_2}{l_3 - l_2} x$	$T_a^{(3)} = T_b$	$K^{(3)}$	$M^{(3)} = \left(\frac{x - l_2}{l_6 - l_2}\right) M$	$S^{(3)} = \left(\frac{x - l_1}{l_6 - l_1}\right) S$
Reticular region ( $l_3 \leq x \leq l_4$ )	$I_4$	$T^{(4)} = \frac{l_4 T_3 - l_3 T_4}{l_4 - l_3} + \frac{T_4 - T_3}{l_4 - l_3} x$	$T_a^{(4)} = T_b$	$K^{(4)}$	$M^{(4)} = \left(\frac{x - l_2}{l_6 - l_2}\right) M$	$S^{(4)} = \left(\frac{x - l_1}{l_6 - l_1}\right) S$
Fatty part of subcutaneous tissue ( $l_4 \leq x \leq l_5$ )	$I_5$	$T^{(5)} = \frac{l_5 T_4 - l_4 T_5}{l_5 - l_4} + \frac{T_5 - T_4}{l_5 - l_4} x$	$T_a^{(5)} = T_b$	$K^{(5)}$	$M^{(5)} = \left(\frac{x - l_2}{l_6 - l_2}\right) M$	$S^{(5)} = \left(\frac{x - l_1}{l_6 - l_1}\right) S$
Muscle part of subcutaneous tissue ( $l_5 \leq x \leq l_6$ )	$I_6$	$T^{(6)} = \frac{l_6 T_5 - l_5 T_6}{l_6 - l_5} + \frac{T_6 - T_5}{l_6 - l_5} x$	$T_a^{(6)} = T_b$	$K^{(6)}$	$M^{(6)} = M$	$S^{(6)} = S$

## 4 Mathematical Solution of the Model

Using Euler-Lagrange formula in equations (1), (2) and (3) we get following variational integral form of bio-heat equations (7) and (8) for the case of males and females respectively.

$$I_{\text{males}}^{(e)} = \frac{1}{2} \int_{l^{(e)}} \left[ K^{(e)} \left( \frac{dT^{(e)}}{dx} \right)^2 + M^{(e)} (T_a - T^{(e)})^2 - 2S^{(e)} T^e \right] dx + \frac{1}{2} [h_{cr}(T - T_{\infty})^2 + 28.47 \times 10^{-5} (0.170 + 0.97b - 36.6)L] \quad (7)$$

$$I_{\text{females}}^{(e)} = \frac{1}{2} \int_{l^{(e)}} \left[ K^{(e)} \left( \frac{dT^{(e)}}{dx} \right)^2 + M^{(e)} (T_a - T^{(e)})^2 - 2S^{(e)} T^e \right] dx + \frac{1}{2} [h_{cr}(T - T_{\infty})^2 + 28.47 \times 10^{-5} (0.170 + 0.77b - 36.6)L] \quad (8)$$

where,  $l$  is the thickness of the skin of the (e) elements.

We write,

$$I_{\text{male}} = \sum_{e=1}^6 I_e \quad (9a)$$

$$I_{\text{female}} = \sum_{e=1}^6 I_e \quad (9b)$$

where,  $I_1$  for stratum corneum,  $I_2$  for stratum germinativum,  $I_3$  for papillary region,  $I_4$  for reticular region,  $I_5$  for fatty layer of subcutaneous tissue and  $I_6$  for muscle layer of subcutaneous tissue.

*Lax-Milgram Theorem:* Let  $V$  be a Hilbert space and a  $(\cdot, \cdot)$  is a symmetrical, continuous and coercive bilinear form. The functional  $I \in V^*$ , dual space of  $V$ , there exists unique  $u \in V$  such that a  $(u, v) = I(v)$  for all  $v \in V$  and,  $u$  is given by  $\min_{v \in H} \left\{ \frac{1}{2} a(v, v) - I(v) \right\}$ ,

where the test function  $v$  is some variation of actual solution  $u$ .

The application of Lax-Milgram theorem in equations (7) and (8) guarantee the existence of the unique solution  $T$  in skin tissue layers. We differentiate system of equations obtained from equations (7) and (8) with regard to the nodal temperatures  $T_0, T_1, T_2, T_3, T_4, T_5, T_6$ . As a next step of finite element method set,

$$\frac{dI}{dT_i} = 0, \text{ where } i = 0, 1, 2, 3, 4, 5 \quad (10)$$

We then get the system of linear equations. The system of linear equations in matrix form is

$$PT = W \quad (11)$$

where,

$$P = \begin{bmatrix} 2D_1 & F_1 & 0 & 0 & 0 & 0 \\ F_1 & 2(E_1 + D_2) & F_2 & 0 & 0 & 0 \\ 0 & F_2 & 2(E_2 + D_3) & F_3 & 0 & 0 \\ 0 & 0 & F_3 & 2(E_3 + D_4) & F_4 & 0 \\ 0 & 0 & 0 & F_4 & 2(E_4 + D_5) & F_5 \\ 0 & 0 & 0 & 0 & F_5 & 2(E_5 + D_6) \end{bmatrix};$$

$$T = \begin{bmatrix} T_0 \\ T_1 \\ T_2 \\ T_3 \\ T_4 \\ T_5 \end{bmatrix}; \quad W = \begin{bmatrix} -B_1 \\ -B_2 \\ -C_2 - B_3 \\ -C_3 - B_4 \\ -C_4 - B_5 \\ -C_5 - B_6 - F_6 T_6 \end{bmatrix}$$

where,

$$P_1 = \frac{S(l_2-l_1)^2}{6(l_3-l_1)}; \quad P_2 = \frac{T_b M}{6(l_5-l_2)}; \quad P_3 = \frac{T_b M}{6(l_5-l_3)}; \quad P_4 = \frac{1}{2} (T_b M + S); \quad R_1 = \frac{K^{(2)}}{(l_2-l_1)}; \quad R_2 = \frac{K^{(3)}}{(l_3-l_2)}$$

$$R_3 = \frac{K^{(4)}}{(l_4-l_3)}; \quad R_4 = \frac{K^{(5)}}{(l_5-l_4)}; \quad R_5 = \frac{K^{(6)}}{(l_6-l_5)}; \quad Q_1 = \frac{M}{(l_3-l_2)(l_5-l_2)}; \quad Q_2 = \frac{M}{(l_4-l_3)(l_5-l_2)}$$

$$Q_3 = \frac{M}{(l_5-l_4)(l_5-l_2)}; \quad Q_4 = \frac{M(l_6-l_5)}{6}; \quad N_1 = \frac{S}{6(l_5-l_1)}; \quad N_2 = \frac{S}{6(l_6-l_1)}$$

$$A_1 = \frac{1}{2} h T_\infty^2; \quad B_1 = LE - h T_\infty; \quad C_1 = 0; \quad D_1 = \frac{1}{2} \left( \frac{K^{(1)}}{l_1} + h \right); \quad E_1 = \frac{K^{(1)}}{2l_1}; \quad F_1 = -\frac{K^{(1)}}{l_1}$$

$$A_2 = 0; \quad B_2 = -P_1; \quad C_2 = -2 P_1; \quad D_2 = \frac{R_1}{2}; \quad E_2 = \frac{R_1}{2}; \quad F_2 = -R_1;$$

$$A_3 = \frac{T_b^2 M (l_3-l_2)^2}{4(l_5-l_2)}; \quad B_3 = -P_2 (l_3-l_2)^2 - N_1 (l_3^2+l_2l_3-2l_2^2-3l_1l_3+3l_1l_2);$$

$$C_3 = P_2 (4l_2l_3 - 2l_2^2 - 2l_3^2) + N_1 (l_2l_3+l_2^2-2l_3^2-3l_1l_2+3l_1l_3);$$

$$D_3 = \frac{1}{2} R_2 + \frac{1}{24} Q_1 (l_3^3-3l_2l_3^2+3l_2^2l_3-l_2^3);$$

$$E_3 = \frac{1}{2} R_2 + \frac{1}{8} Q_1 (l_3-l_2)^3; \quad F_3 = -R_2 + \frac{1}{12} Q_1 (l_3-l_2)^3;$$

$$A_4 = \frac{T_b^2 M}{4(l_5-l_2)} (l_4^2-l_3^2-2l_2l_4+2l_2l_3);$$

$$A_5 = \frac{T_b^2 M}{4(l_5-l_2)} (l_5^2-l_4^2-2l_2l_5+2l_2l_4);$$

$$B_4 = -P_2 (l_4^2+l_3l_4-2l_3^2-3l_2l_4+3l_2l_3) - N_1 (l_4^2+l_3l_4-2l_3^2-3l_1l_4+3l_1l_2);$$

$$B_5 = -P_3 (l_5^2+l_4l_5-2l_4^2-3l_2l_5+3l_2l_4) - N_1 (l_5^2+l_4l_5-2l_4^2-3l_1l_5+3l_1l_2);$$

$$C_4 = P_2(l_3l_4+l_3^2-2l_4^2-3l_2l_3+3l_2l_4) + N_1(l_3l_4+l_3^2-2l_4^2-3l_1l_3+3l_1l_4);$$

$$C_5 = P_3(l_4l_5+l_4^2-2l_5^2-3l_2l_4+3l_2l_5) + N_1(l_4l_5+l_4^2-2l_5^2-3l_1l_4+3l_1l_5);$$

$$D_4 = \frac{1}{2} R_3 + \frac{1}{24} Q_2(l_4^3+l_3l_4^2-5l_3^2l_4+3l_3^3-4l_2l_4^2-4l_2l_3^2+8l_2l_3l_4);$$

$$D_5 = \frac{1}{2} R_4 + \frac{1}{24} Q_3(l_5^3+l_4l_5^2-5l_4^2l_5+3l_4^3-4l_2l_5^2-4l_2l_4^2+8l_2l_4l_5);$$

$$E_4 = \frac{1}{2} R_3 + \frac{1}{24} Q_2(l_3^2l_4+l_3^3-5l_3l_4^2+3l_4^3-4l_2l_4^2-l_2l_3^2+8l_2l_3l_4);$$

$$E_5 = \frac{1}{2} R_4 + \frac{1}{24} Q_3(l_4^2l_5+l_4^3-5l_4l_5^2+3l_5^3-4l_2l_5^2-l_2l_4^2+8l_2l_4l_5);$$

$$F_4 = -R_3 - \frac{1}{12} Q_2(l_3l_4^2+l_3^2l_4-l_4^3-l_3^3-4l_2l_3l_4+2l_2l_4^2+2l_2l_3^2);$$

$$F_5 = -R_4 - \frac{1}{12} Q_3(l_4l_5^2+l_4^2l_5-l_5^3-l_4^3-4l_2l_4l_5+2l_2l_5^2+2l_2l_4^2);$$

$$A_6 = \frac{1}{2} MT_b^2 (l_6-l_5); \quad B_6 = -P_4 (l_6-l_5); \quad C_6 = P_4 (l_5-l_6);$$

$$D_6 = \frac{1}{2} R_5 + Q_4; \quad E_6 = D_6; \quad F_6 = -R_5 + Q_4.$$

But parameter E, which is replaced as the relations mentioned in equation (1).

## 5 Results and Discussion

The male sex hormone testosterone can increase the metabolic rate about 10% - 15%. But the females sex hormone estrogen may increase the metabolic rate a small amount but usually not enough to be significant. Males usually have higher metabolic rate than females of the same age because males tend to have a higher proportional of lean body mass than females of the same age. Conversely, females tend to have a higher proportional of fat cells and fat cells have a lower metabolic rate than lean muscle cells. But metabolic rate increases during pregnancy and lactation due to high energy requirement of producing fetal tissues than breast milk [8]. The luteal phase metabolic rate is about 5%-6% higher than follicular phase of females [9]. In general females have a metabolic rate about 5% - 10% lower than males. The skin blood flow is lower in the luteal phase ( $0.101 \pm 0.008 l / m^2 / min$ ) compared to the follicular phase ( $0.131 \pm 0.015 l / m^2 / min$ ) [10].

So we have been considered different metabolic rates and perfusion rates in case of females luteal and follicular phase and males. The following values have been assigned to each physical and physiological parameter in each sub region of dermal part [11,12,13].

$$K^{(1)} = 0.20934w/m^0C, \quad K^{(2)} = 0.20934w/m^0C, \quad K^{(3)} = 0.31401w/m^0C, \quad K^{(4)} = 0.31401w/m^0C, \quad K^{(5)} = 0.34879w/m^0C, \quad K^{(6)} = 0.41855w/m^0C, \quad L = 2.4 \times 10^6 J/kg, \quad h = 6.2802w/m^2 \cdot 0C, \quad \rho = 1050kg/m^3, \quad c = 3475.044J/kg \cdot 0C, \quad M_{male} = 2197.39w/m^3 / 0C, \quad M_{luteal} = 2197.39w/m^3 / 0C, \quad M_{follicular} = 1538.17w/m^3 / 0C, \quad S_{male} = 744w/m^2C, \quad S_{luteal} = 707w/m^2C, \quad S_{follicular} = 665w/m^2C.$$

The superficial epidermis is approximately (75- 150  $\mu m$ ) in thickness. The second layer is the dermis which is approximately 1 - 4 mm. The thickness of epidermis is up to 0.6 mm in the palms and soles. The third layer is subcutaneous tissue which is composed of loose fatty connective tissue. The thickness of subcutaneous tissue varies considerably over the surface of the body [14]. The thickness of subcutaneous part varies with age, sex, race, endocrine, and nutritional status of the individual. It acts as an insulating layer and a protective cushion and constitutes amount 10% of the body weight [15].

The thicknesses of dermal layers (m) considered in this model are  $l_1= 0.0005$ ,  $l_2= 0.001$ ,  $l_3= 0.002$ ,  $l_4= 0.0035$ ,  $l_5= 0.0060$ ,  $l_6= 0.01$  of females and  $l_1= 0.0005$ ,  $l_2= 0.001$ ,  $l_3= 0.002$ ,  $l_4= 0.0035$ ,  $l_4= 0.0055$ ,  $l_5= 0.009$  of males.

Using parameters values in the system of equations (11), the results of the analysis for temperature distribution are presented through the graphs in the Figs. 2 and 3 for steady state case.

The Fig. 2 represents the tissue temperature differences of females during luteal and follicular phases and males at  $T_\infty = 30^\circ C$ . The males tissue temperatures  $T_0, T_1, T_2, T_3, T_4$ , are increased by around  $0.12^\circ C$  and  $T_5$  is increased by around  $0.05^\circ C$  respectively in comparison to females luteal phase. Accordingly the rises of males tissue temperatures  $T_0, T_1, T_2, T_3, T_4$ , and  $T_5$  are observed by  $0.80^\circ C, 0.75^\circ C, 0.69^\circ C, 0.60^\circ C, 0.51^\circ C$  and  $0.27^\circ C$  in comparison to females follicular phase at atmospheric temperature  $T_\infty = 30^\circ C$ . Furthermore, it is observed that the tissue temperatures  $T_0, T_1, T_2, T_3, T_4$ , and  $T_5$  are higher in the luteal phase of the menstrual cycle by an average of  $0.68^\circ C, 0.63^\circ C, 0.57^\circ C, 0.48^\circ C, 0.39^\circ C$  and  $0.22^\circ C$  as compared to the follicular phase.

The Fig. 3. delineates the tissue temperature difference of females during the follicular and luteal phases and males at  $T_\infty = 45^\circ C$ . The males nodal temperatures  $T_0, T_1, T_2, T_3, T_4$  are decreased by around  $0.07^\circ C$  and  $T_5$  is decreased by  $0.04^\circ C$  respectively in comparison to luteal phase of females. Accordingly  $T_0, T_1, T_2, T_3, T_4$  and  $T_5$  of males are increased by  $0.87^\circ C, 0.79^\circ C, 0.71^\circ C, 0.60^\circ C, 0.45^\circ C$  and  $0.26^\circ C$  respectively in comparison to follicular phase of females. Moreover, it is revealed that nodal temperatures  $T_0, T_1, T_2, T_3, T_4$  and  $T_5$  are higher in the luteal phase by an average of  $0.94^\circ C, 0.86^\circ C, 0.78^\circ C, 0.67^\circ C, 0.52^\circ C$  and  $0.29^\circ C$  respectively in comparison to the follicular phase.

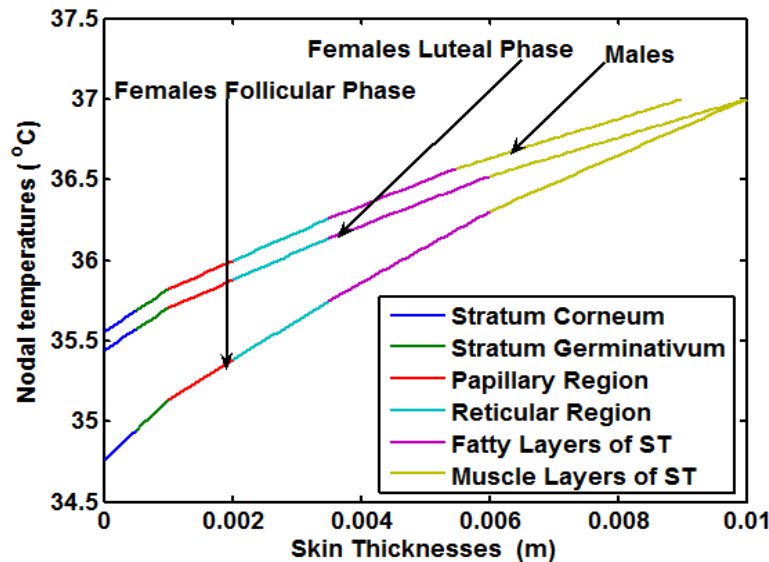

Fig. 2. Tissue temperatures of females follicular and luteal phases and males at  $T_\infty = 30^\circ C$ .



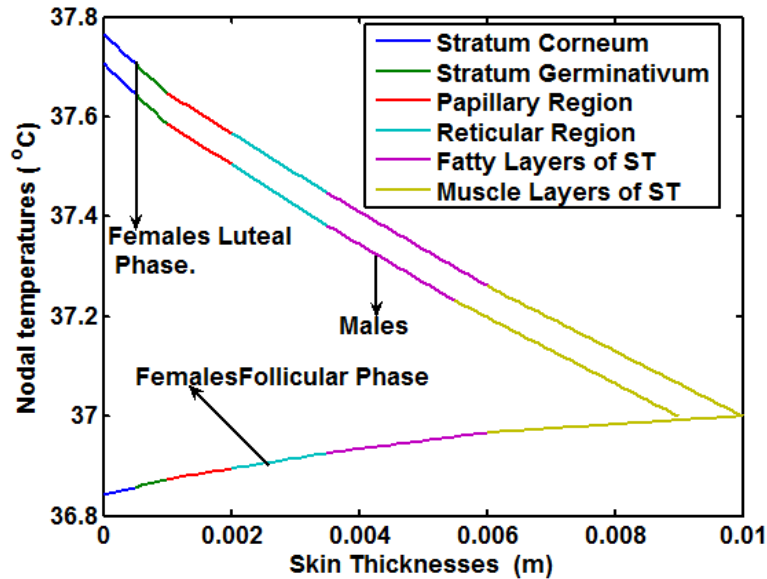

Fig. 3. Tissue temperatures of females follicular and luteal phases and males at  $T_{\infty} = 45^{\circ}\text{C}$ .

The Fig. 4 presents the tissue temperature difference of females during the follicular and luteal phases and males at  $T_{\infty} = 55^{\circ}\text{C}$ . The males nodal temperatures  $T_0, T_1, T_2, T_3, T_4$  are decreased by around  $0.30^{\circ}\text{C}$  and  $T_5$  is decreased by  $0.13^{\circ}\text{C}$  respectively in comparison to luteal phase of females. Accordingly  $T_0, T_1, T_2, T_3, T_4$  and  $T_5$  of males are increased by  $0.86^{\circ}\text{C}, 0.77^{\circ}\text{C}, 0.69^{\circ}\text{C}, 0.57^{\circ}\text{C}, 0.40^{\circ}\text{C}$  and  $0.25^{\circ}\text{C}$  respectively in comparison to follicular phase of females. Furthermore, it is revealed that nodal temperatures  $T_0, T_1, T_2, T_3, T_4$  and  $T_5$  are higher in the luteal phase by an average of  $1.18^{\circ}\text{C}, 1.09^{\circ}\text{C}, 0.99^{\circ}\text{C}, 0.86^{\circ}\text{C}, 0.67^{\circ}\text{C}$  and  $0.38^{\circ}\text{C}$  respectively in comparison to the follicular phase.

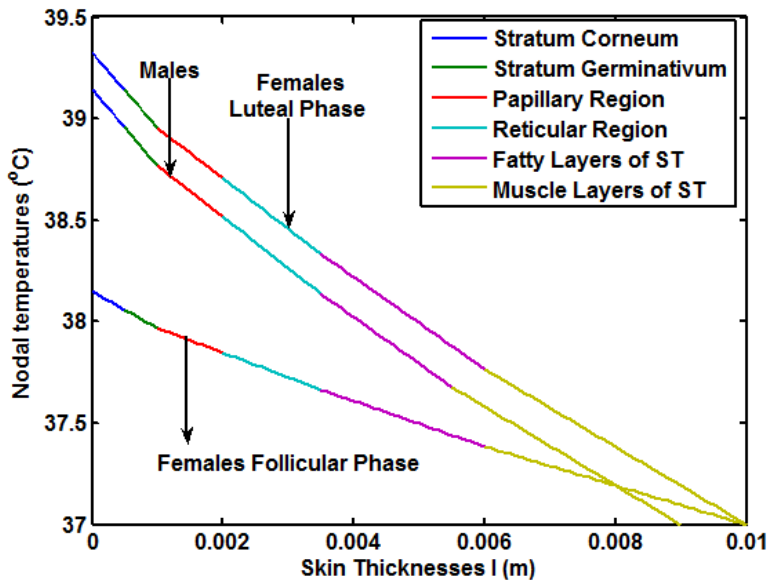

Fig. 4. Tissue temperatures of females follicular and luteal phases and males at  $T_{\infty} = 55^{\circ}\text{C}$ .

The results obtained in the present study confirm that the skin temperature in males is slightly higher relative to females follicular and luteal phases when atmospheric temperature  $T_{\infty}$  falls below the body core. This may be due to less sweating effect in heat loss in our body as atmospheric temperature is below than our body temperature. Consequently males tissue temperature is slightly lower as compared to luteal phase of females when  $T_{\infty}$  exceeds above  $37^{\circ}\text{C}$ . The sweating effect is high during heat loss by our body when atmospheric temperature is above body core temperature. The reason for higher temperature during the luteal phase may be of thermogenic properties of progesterone. But females follicular phase temperature is lower as compared to females luteal phase and males body temperature. The lower skin temperature during the follicular phase may be due to the concentration of estrogen because estrogen contributes for cooling effect while atmospheric temperature is above or below body core temperature.

## 6 Conclusion

The study is simulated comparative steady state tissue temperature on one dimensional variational finite element models of males and during follicular and luteal phases of females. The analysis presents that during the luteal phase of females, the tissue temperature is lower as compared to males when  $T_{\infty}$  falls below body core temperature. Also, females luteal phase temperature is slightly higher as compared to males when  $T_{\infty}$  exceeds body core temperature. But females follicular phase temperature is lower as compared to females luteal phase and males body temperature either  $T_{\infty}$  is greater or less body core. The above differences of females compared to males under same atmospheric conditions may be the causes of females hormonal variation during the menstrual cycle phases.

The information extracted from this model will help for further investigation in thermal disturbances occur in the layers of dermal part due to external thermal loads to obtain a more accurate model for further applications. It can be useful for extensive parametric studies in order to characterize the stability of various treatment parameters.

## Competing Interests

Authors have declared that no competing interests exist.

## References

- [1] Bittel J, Henane R. Comparison of thermal exchanges in men and women under neutral and hot conditions. *J. Appl. Physiol.* 1975;250:475-489.
- [2] Goldman RF. Standards for human exposure to heat. *Environmental Ergonomics*, New York. 1998; 38-991.
- [3] Daniel G, Ghee PK. Dose sex has an independent effect on thermo effectors responses during exercise in the heat? *J. Physiology (Jp. physoc.org)*, Invited Topical Review; 2014.
- [4] Sarah AN. Physiology responses of women to thermal stress: A review. *Medicine and Science in Sports.* 1978;10(4):250-255.
- [5] Nadel ER, Bullard RW, Stolwijk JAJ. Importance of skin temperature in the regulation of sweating. *J. Appl. Physiol.* 1979;46:430-437.
- [6] Hoppe PR. Heat balancing modeling. *Institute and Outpatient Clinic for Occupational Medicine, Experientia.* 1993;49:741-746.

- [7] Pennes HH. Analysis of tissue and arterial blood temperatures in the resting human forearm. *J. Appl. Physiol.* 1948;1:93-122.
- [8] Guyton C, Hall E. Text book of medical physiology. India, Elsevier, Ninth Edition; 2009.
- [9] Hessemer V, Bruck K. Influence of menstrual cycle on shivering, skin blood flow and sweating responses measured at night. *Journal of Applied Physiology.* 1985;59:1902-1210.
- [10] Frascrolo P, Schutz Y, Jequier. Decreased thermal conductance during the luteal phase of the menstrual cycle in women. *Journal of Applied Physiology.* 1990;69:2029-2033.
- [11] Acharya S, Gurung DB, Saxena VP. Transient temperature distribution in human males and female body due to variation in perfusion effect. *International Journal of Applied Mathematics, Recent Science Publication.* 2014;29:1263-1270.
- [12] Acharya S, Gurung DB, Saxena VP. Effect of metabolic reactions on thermoregulation in human males and females body, *Journal of applied mathematics, Scientific Research Publishing.* 2013;(5A)4: 39-48.
- [13] Acharya S, Gurung DB, Saxena VP. Human males and females body thermoregulation: Perfusion effect analysis. *Journal of Thermal Biology, Elsevier.* 2014;45:30–36.
- [14] Odland GF. Structure of the skin, Physiology, biochemistry and molecular biology of the skin, second edition. Oxford University Press, Oxford; 1991.
- [15] Burton JL, Cunliffe WJ. Subcutaneous Fat: text book of dermatology, fifth edition. Blackwell Scientific Publications, New York; 1992.

---

© 2016 Acharya et al.; This is an Open Access article distributed under the terms of the Creative Commons Attribution License (<http://creativecommons.org/licenses/by/4.0>), which permits unrestricted use, distribution, and reproduction in any medium, provided the original work is properly cited.

**Peer-review history:**

The peer review history for this paper can be accessed here (Please copy paste the total link in your browser address bar)

<http://sciencedomain.org/review-history/11985>